

# Smart Cities PRO

## Technical Guide

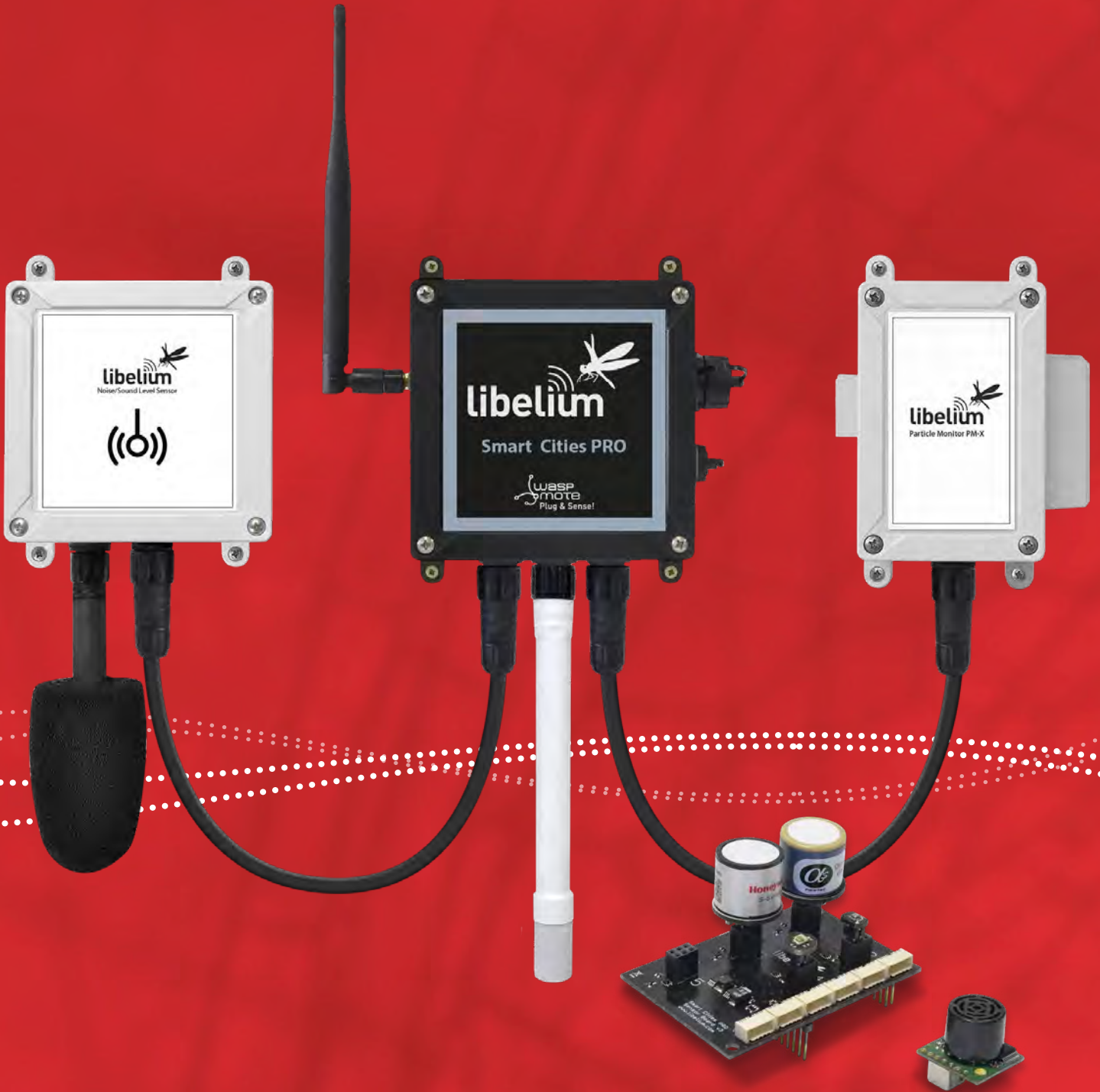

Document version: v7.6 - 02/2019  
© Libelium Comunicaciones Distribuidas S.L.

## INDEX

<b>1. General</b> .....	<b>5</b>
1.1. General and safety information .....	5
1.2. Conditions of use .....	6
<b>2. New version: Smart Cities PRO v3.0</b> .....	<b>7</b>
<b>3. Waspote Plug &amp; Sense!</b> .....	<b>8</b>
<b>4. Hardware</b> .....	<b>27</b>
4.1. General description .....	27
4.2. Specifications.....	27
4.3. Electrical characteristics .....	27
<b>5. Sensors</b> .....	<b>28</b>
5.1. Temperature, Humidity and Pressure Sensor.....	28
5.1.1. Specifications .....	28
5.1.2. Measurement process.....	29
5.1.3. Socket .....	30
5.2. Ultrasound sensor probe (MaxSonar® from MaxBotix™).....	31
5.2.1. Specifications .....	31
5.2.2. Measurement Process.....	33
5.2.3. Socket .....	33
5.3. Luminosity (Luxes accuracy) Sensor.....	34
5.3.1. Specifications .....	34
5.3.2. Measurement process.....	34
5.3.3. Socket .....	34
5.4. Particle Matter (PM1 / PM2.5 / PM10) - Dust Sensor .....	35
5.4.1. Specifications .....	35
5.4.2. Particle matter: the parameter .....	36
5.4.3. Measurement process.....	36
5.5. Noise / Sound Level Sensor .....	37
5.5.1. Specifications of the Sound Level Sensor probe .....	37
5.5.2. Specifications of the enclosure.....	37
5.5.3. Sound pressure level measurement.....	37
5.5.4. Equivalent continuous sound level .....	38
5.5.5. The A-weighting.....	38
5.5.6. International standard IEC 61672-1:2013 .....	39
5.5.7. Measurement process.....	39
5.5.8. Calibration Tests.....	39
5.5.9. Mounting the Noise / Sound Level Sensor and supplying power .....	41
5.6. Carbon Monoxide (CO) Gas Sensor for high concentrations [Calibrated].....	46
5.6.1. Specifications .....	46

5.6.2. Cross-sensitivity data .....	47
5.7. Carbon Monoxide (CO) Gas Sensor for low concentrations [Calibrated] .....	48
5.7.1. Specifications .....	48
5.7.2. Cross-sensitivity data .....	49
5.8. Carbon Dioxide (CO <sub>2</sub> ) Gas Sensor [Calibrated].....	50
5.8.1. Specifications .....	50
5.9. Molecular Oxygen (O <sub>2</sub> ) Gas Sensor [Calibrated].....	51
5.9.1. Specifications .....	51
5.10. Ozone (O <sub>3</sub> ) Gas Sensor [Calibrated].....	52
5.10.1. Specifications .....	52
5.10.2. Cross-sensitivity data .....	53
5.11. Nitric Oxide (NO) Gas Sensor for low concentrations [Calibrated] .....	54
5.11.1. Specifications .....	54
5.11.2. Cross-sensitivity data .....	55
5.12. Nitric Dioxide (NO <sub>2</sub> ) high accuracy Gas Sensor [Calibrated] .....	56
5.12.1. Specifications .....	56
5.12.2. Cross-sensitivity data .....	57
5.13. Sulfur Dioxide (SO <sub>2</sub> ) high accuracy Gas Sensor [Calibrated] .....	58
5.13.1. Specifications .....	58
5.13.2. Cross-sensitivity data .....	59
5.14. Ammonia (NH <sub>3</sub> ) Gas Sensor for low concentrations [Calibrated] .....	60
5.14.1. Specifications .....	60
5.14.2. Cross-sensitivity data .....	61
5.15. Ammonia (NH <sub>3</sub> ) Gas Sensor for high concentrations [Calibrated].....	62
5.15.1. Specifications .....	62
5.15.2. Cross-sensitivity data .....	63
5.16. Methane (CH <sub>4</sub> ) and Combustible Gas Sensor [Calibrated] .....	64
5.16.1. Specifications .....	64
5.16.2. Sensitivity data .....	65
5.17. Molecular Hydrogen (H <sub>2</sub> ) Gas Sensor [Calibrated].....	66
5.17.1. Specifications .....	66
5.17.2. Cross-sensitivity data .....	67
5.18. Hydrogen Sulfide (H <sub>2</sub> S) Gas Sensor [Calibrated] .....	68
5.18.1. Specifications .....	68
5.18.2. Cross-sensitivity data .....	69
5.19. Hydrogen Chloride (HCl) Gas Sensor [Calibrated] .....	70
5.19.1. Specifications .....	70
5.19.2. Cross-sensitivity data .....	71
5.20. Hydrogen Cyanide (HCN) Gas Sensor [Calibrated] .....	72
5.20.1. Specifications .....	72
5.20.2. Cross-sensitivity data .....	73

---

5.21. Phosphine (PH <sub>3</sub> ) Gas Sensor [Calibrated] .....	74
5.21.1. Specifications .....	74
5.21.2. Cross-sensitivity data .....	75
5.22. Ethylene Oxide (ETO) Gas Sensor [Calibrated] .....	76
5.22.1. Specifications .....	76
5.22.2. Cross-sensitivity data .....	77
5.23. Chlorine (Cl <sub>2</sub> ) Gas Sensor [Calibrated] .....	78
5.23.1. Specifications .....	78
5.23.2. Cross-sensitivity data .....	79
5.24. Important notes for Calibrated Sensors .....	80
<b>6. Board configuration and programming .....</b>	<b>88</b>
6.1. Hardware configuration .....	88
6.2. API .....	88
6.2.1. Before starting to program .....	88
6.2.2. Gases sensors .....	88
6.2.3. Temperature, humidity and pressure sensor (BME280) .....	89
6.2.4. Luxes sensor .....	89
6.2.5. Ultrasound sensor .....	90
6.2.6. Particle Matter sensor .....	91
<b>7. Consumption .....</b>	<b>94</b>
7.1. Consumption table .....	94
<b>8. API changelog .....</b>	<b>95</b>
<b>9. Documentation changelog .....</b>	<b>96</b>
<b>10. Certifications .....</b>	<b>97</b>
<b>11. Maintenance .....</b>	<b>98</b>
<b>12. Disposal and recycling .....</b>	<b>99</b>

# 1. General

## Important:

- All documents and any examples they contain are provided as-is and are subject to change without notice. Except to the extent prohibited by law, Libelium makes no express or implied representation or warranty of any kind with regard to the documents, and specifically disclaims the implied warranties and conditions of merchantability and fitness for a particular purpose.
- The information on Libelium's websites has been included in good faith for general informational purposes only. It should not be relied upon for any specific purpose and no representation or warranty is given as to its accuracy or completeness.

## 1.1. General and safety information

- In this section, the term "WaspMote" encompasses both the WaspMote device itself and its modules and sensor boards.
- Read through the document "General Conditions of Libelium Sale and Use".
- Do not allow contact of metallic objects with the electronic part to avoid injuries and burns.
- NEVER submerge the device in any liquid.
- Keep the device in a dry place and away from any liquid which may spill.
- WaspMote consists of highly sensitive electronics which is accessible to the exterior, handle with great care and avoid bangs or hard brushing against surfaces.
- Check the product specifications section for the maximum allowed power voltage and amperage range and consequently always use a current transformer and a battery which works within that range. Libelium is only responsible for the correct operation of the device with the batteries, power supplies and chargers which it supplies.
- Keep the device within the specified range of temperatures in the specifications section.
- Do not connect or power the device with damaged cables or batteries.
- Place the device in a place only accessible to maintenance personnel (a restricted area).
- Keep children away from the device in all circumstances.
- If there is an electrical failure, disconnect the main switch immediately and disconnect that battery or any other power supply that is being used.
- If using a car lighter as a power supply, be sure to respect the voltage and current data specified in the "Power Supplies" section.
- If using a battery in combination or not with a solar panel as a power supply, be sure to use the voltage and current data specified in the "Power supplies" section.
- If a software or hardware failure occurs, consult the Libelium Web Development section.
- Check that the frequency and power of the communication radio modules together with the integrated antennas are allowed in the area where you want to use the device.
- WaspMote is a device to be integrated in a casing so that it is protected from environmental conditions such as light, dust, humidity or sudden changes in temperature. The board supplied "as is" is not recommended for a final installation as the electronic components are open to the air and may be damaged.

## 1.2. Conditions of use

- Read the “General and Safety Information” section carefully and keep the manual for future consultation.
- Use Waspote in accordance with the electrical specifications and the environment described in the “Electrical Data” section of this manual.
- Waspote and its components and modules are supplied as electronic boards to be integrated within a final product. This product must contain an enclosure to protect it from dust, humidity and other environmental interactions. In the event of outside use, this enclosure must be rated at least IP-65.
- Do not place Waspote in contact with metallic surfaces; they could cause short-circuits which will permanently damage it.

Further information you may need can be found at <http://www.libelium.com/development/waspote>

The “General Conditions of Libelium Sale and Use” document can be found at:

[http://www.libelium.com/development/waspote/technical\\_service](http://www.libelium.com/development/waspote/technical_service)

## 2. New version: Smart Cities PRO v3.0

This guide explains the new Smart Cities Sensor Board v3.0. This board was designed for our new product lines Waspote v15 and Plug & Sense! v15, released on October 2016.

The previous version of this board (Smart Cities v2.0) was designed for Waspote v12 and Plug & Sense! v12, and it is NOT recommended to mix product generations. If you are using previous versions of our products, please use the corresponding guides, available on our [Development website](#).

You can get more information about the generation change on the document "[New generation of Libelium product lines](#)".

Differences of Smart Cities PRO v3.0 with the previous version:

- Added the new Noise Level Sensor, able to read LeqA (integrated equivalent continuous sound level, A-weighted) in dBA. The sensor achieves high accuracy in a wide range of frequencies.
- I2C sockets allow the connection of digital sensors, even gas sensors from Gases PRO, Temperature, Humidity and Pressure sensor or Luxes and Ultrasound sensors.
- The Particle Matter – Dust Sensor (PM1 / PM2.5 / PM10) is now available on this board.
- New connectors to improve the Plug & Sense! wiring, making it more robust.
- Added an I2C isolator chip to avoid affecting to the Waspote I2C bus.

### 3. Wasmote Plug & Sense!

The Wasmote Plug & Sense! line allows you to easily deploy Internet of Things networks in an easy and scalable way, ensuring minimum maintenance costs. The platform consists of a robust waterproof enclosure with specific external sockets to connect the sensors, the solar panel, the antenna and even the USB cable in order to reprogram the node. It has been specially designed to be scalable, easy to deploy and maintain.

**Note:** For a complete reference guide download the “Wasmote Plug & Sense! Technical Guide” in the [Development section](#) of the [Libelium website](#).

#### 3.1. Features

- Robust waterproof IP65 enclosure
- Add or change a sensor probe in seconds
- Solar powered external panel option
- Radios available: 802.15.4, 868 MHz, 900 MHz, WiFi, 4G, Sigfox and LoRaWAN
- Over the air programming (OTAP) of multiple nodes at once (via WiFi or 4G radios)
- Special holders and brackets ready for installation in street lights and building fronts
- Graphical and intuitive interface Programming Cloud Service
- Built-in, 3-axes accelerometer
- External, contactless reset with magnet
- Optional industrial protocols: RS-485, Modbus, CAN Bus
- Optional GPS receiver
- Optional External Battery Module
- External SIM connector for the 4G models
- Fully certified: CE (Europe), FCC (USA), IC (Canada), ANATEL (Brazil), RCM (Australia), PTCRB (USA, cellular connectivity), AT&T (USA, cellular connectivity)



Figure: Wasmote Plug & Sense!



## 3.2. General view

This section shows main parts of Waspote Plug & Sense! and a brief description of each one. In later sections all parts will be described deeply.

### 3.2.1. Specifications

- **Material:** polycarbonate
- **Sealing:** polyurethane
- **Cover screws:** stainless steel
- **Ingress protection:** IP65
- **Impact resistance:** IK08
- **Rated insulation voltage AC:** 690 V
- **Rated insulation voltage DC:** 1000 V
- **Heavy metals-free:** Yes
- **Weatherproof:** true - nach UL 746 C
- **Ambient temperature (min.):** -30 °C\*
- **Ambient temperature (max.):** 70 °C\*
- **Approximated weight:** 800 g

\* Temporary extreme temperatures are supported. Regular recommended usage: -20, +60 °C.

In the pictures included below it is shown a general view of Waspote Plug & Sense! main parts. Some elements are dedicated to node control, others are designated to sensor connection and other parts are just identification elements. All of them will be described along this guide.

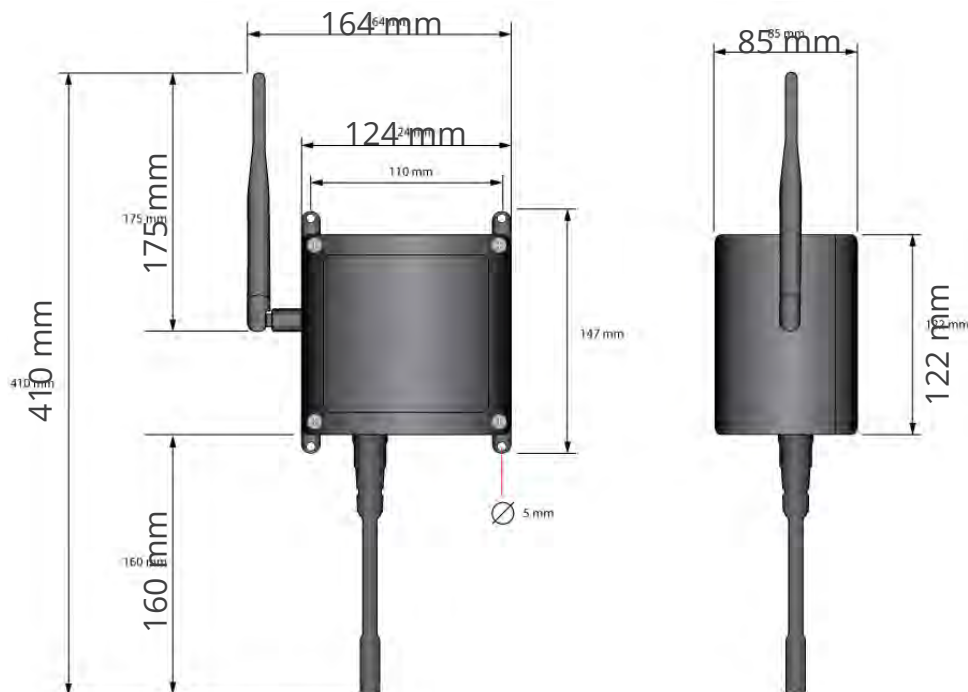

Figure: Main view of Waspote Plug & Sense!

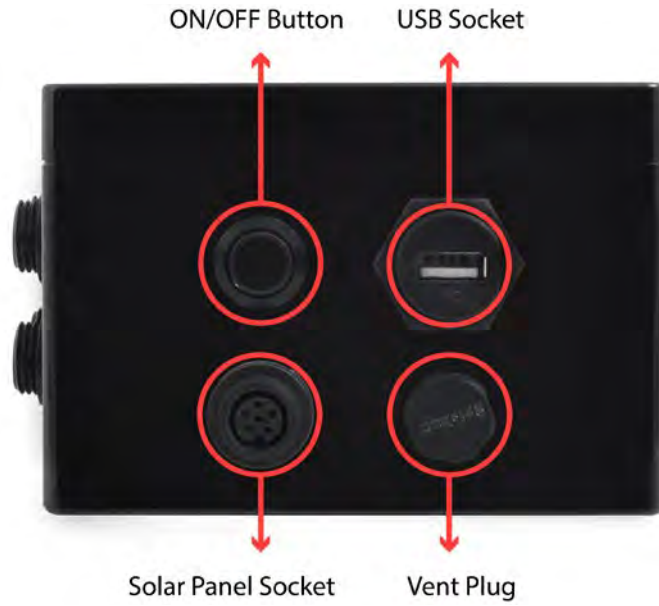
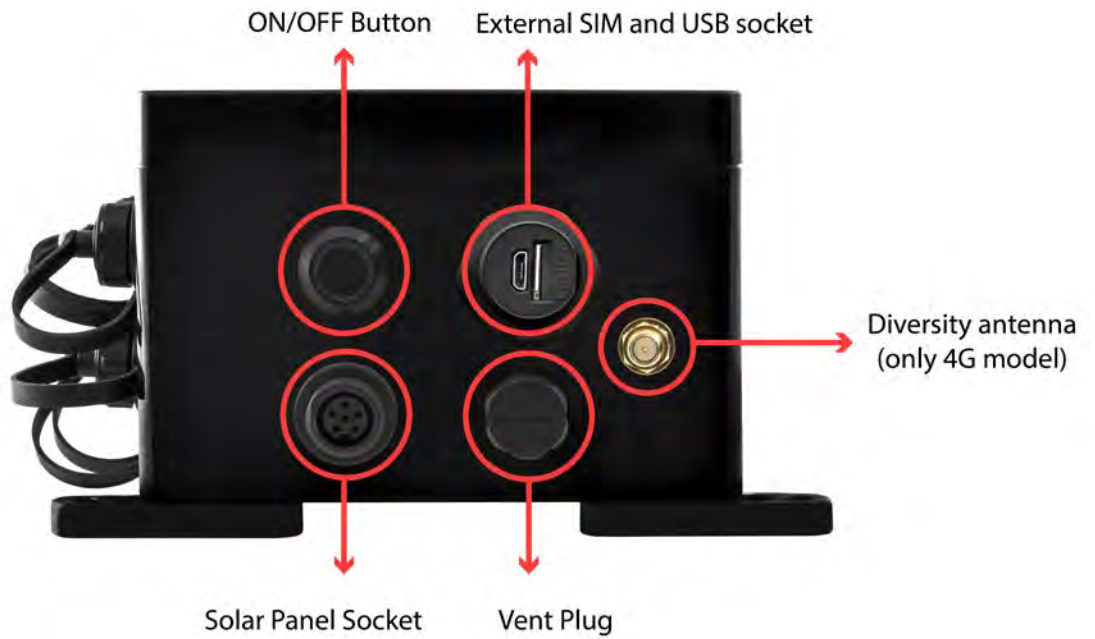

Figure: Control side of the enclosure



Control side of the enclosure for 4G model

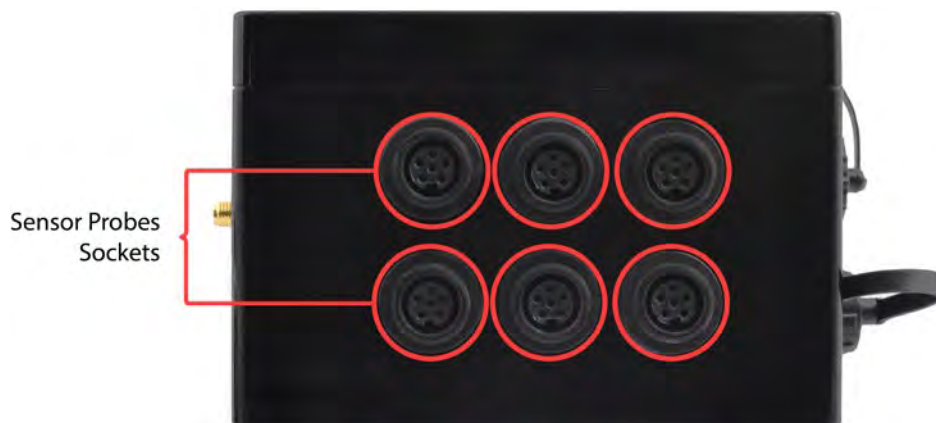

Figure: Sensor side of the enclosure



Figure: Antenna side of the enclosure



Figure: Front view of the enclosure



Figure: Back view of the enclosure



Figure: Warranty stickers of the enclosure

**Important note:** Do not handle black stickers seals of the enclosure (Warranty stickers). Their integrity is the proof that Waspote Plug & Sense! has not been opened. If they have been handled, damaged or broken, the warranty is automatically void.

### 3.2.2. Parts included

Next picture shows Waspote Plug & Sense! and all of its elements. Some of them are optional accessories that may not be included.



Figure: Waspote Plug & Sense! accessories: 1 enclosure, 2 sensor probes, 3 external solar panel, 4 USB cable, 5 antenna, 6 cable ties, 7 mounting feet (screwed to the enclosure), 8 extension cord, 9 solar panel cable, 10 wall plugs & screws

### 3.2.3. Identification

Each Waspote model is identified by stickers. Next figure shows front sticker.

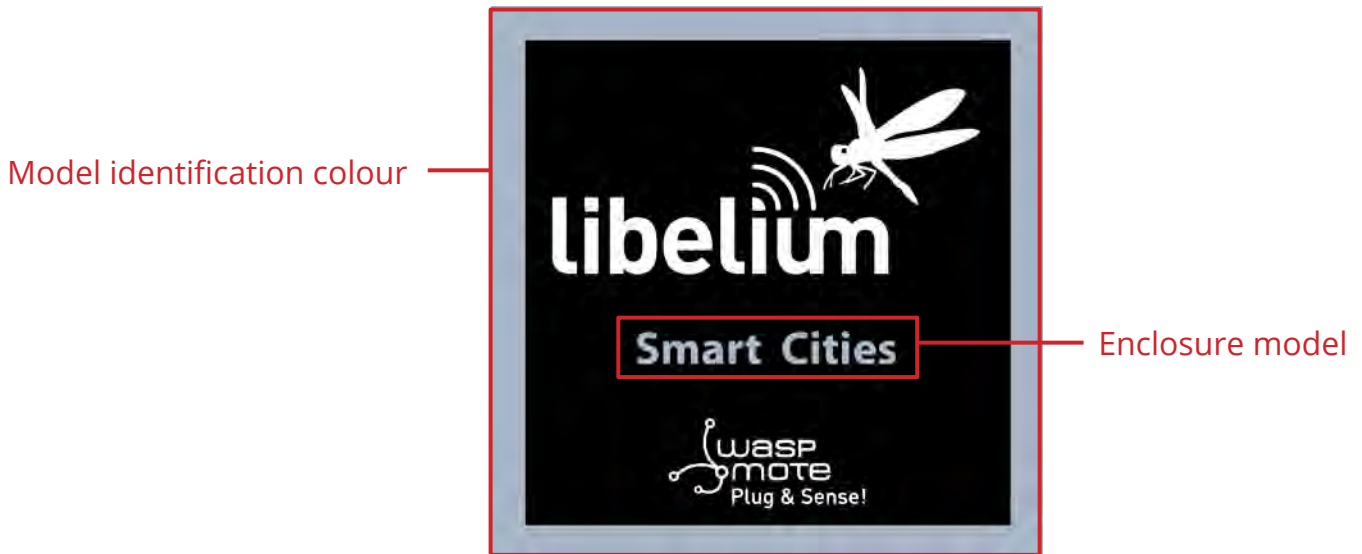

Figure: Front sticker of the enclosure

There are many configurations of Waspote Plug & Sense! line, all of them identified by one unique sticker. Next image shows all possibilities.



Figure: Different front stickers

Moreover, Waspote Plug & Sense! includes a back sticker where it is shown identification numbers, radio MAC addresses, etc. It is highly recommended to annotate this information and save it for future maintenance. Next figure shows it in detail.





	<b>Brand name:</b> Libelium	<b>Country of origin:</b> Spain
Plug & Sense! model	<b>Model:</b> Waspote Plug & Sense! WiFi	<b>Version:</b> 1.0
Device serial number	<b>Serial ID:</b> xxxxxxxxx	
Battery type	<b>Battery:</b> 6600 mA·h rechargeable	
Radio type	<b>Radio:</b> WiFi	
Sensor board and extra info	<b>Info:</b> Smart Environment	
	<b>FCC ID:</b> XKM-WPS-WIFI-V1	
	<b>IC:</b> 8472A-WPSWIFIV1	
	<p>This device complies with Part 15 of the FCC Rules. Operation is subject to the following two conditions: (1) this device may not cause harmful interference, and (2) this device must accept any interference received, including interference that may cause undesired operation.</p> <p>Este equipamento opera em caráter secundário, isto é, não tem direito a proteção contra interferência prejudicial, mesmo de estações do mesmo tipo, e não pode causar interferência a sistemas operando em caráter primário.</p>	
Certifications info		

Figure: Back sticker

Sensor probes are identified too by a sticker showing the measured parameter and the sensor manufacturer reference.



Figure: Sensor probe identification sticker

### 3.3. Sensor probes

Sensor probes can be easily attached by just screwing them into the bottom sockets. This allows you to add new sensing capabilities to existing networks just in minutes. In the same way, sensor probes may be easily replaced in order to ensure the lowest maintenance cost of the sensor network.



*Figure: Connecting a sensor probe to Waspote Plug & Sense!*

Go to the [Plug & Sense! Sensor Guide](#) to know more about our sensor probes.

### 3.4. Solar powered

The battery can be recharged using the waterproof USB cable but also the external solar panel option.

The external solar panel is mounted on a 45° holder which ensures the maximum performance of each outdoor installation.



*Figure: Waspote Plug & Sense! powered by an external solar panel*



### 3.5. External Battery Module

The External Battery Module (EBM) is an accessory to extend the battery life of Plug & Sense!. The extension period may be from months to years depending on the sleep cycle and radio activity. The daily charging period is selectable among 5, 15 and 30 minutes with a selector switch and it can be combined with a solar panel to extend even more the node's battery lifetime.

**Note:** Nodes using solar panel can keep using it through the External Battery Module. The EBM is connected to the solar panel connector of Plug & Sense! and the solar panel unit is connected to the solar panel connector of the EBM.

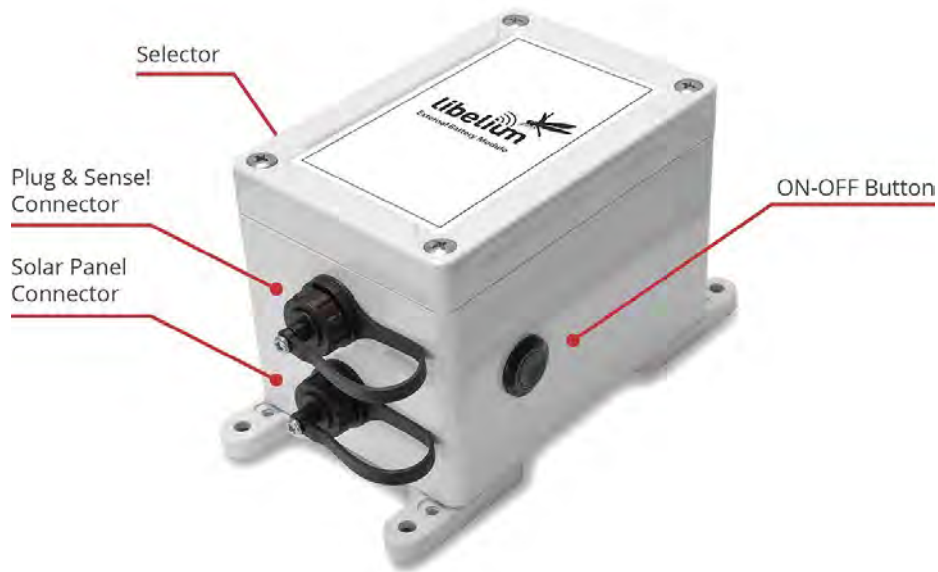

Figure: Plug & Sense! with External Battery Module



Figure: Plug & Sense! with External Battery Module and solar panel

### 3.6. Programming the Nodes

Waspote Plug & Sense! can be reprogrammed in two ways:

The basic programming is done from the USB port. Just connect the USB to the specific external socket and then to the computer to upload the new firmware.

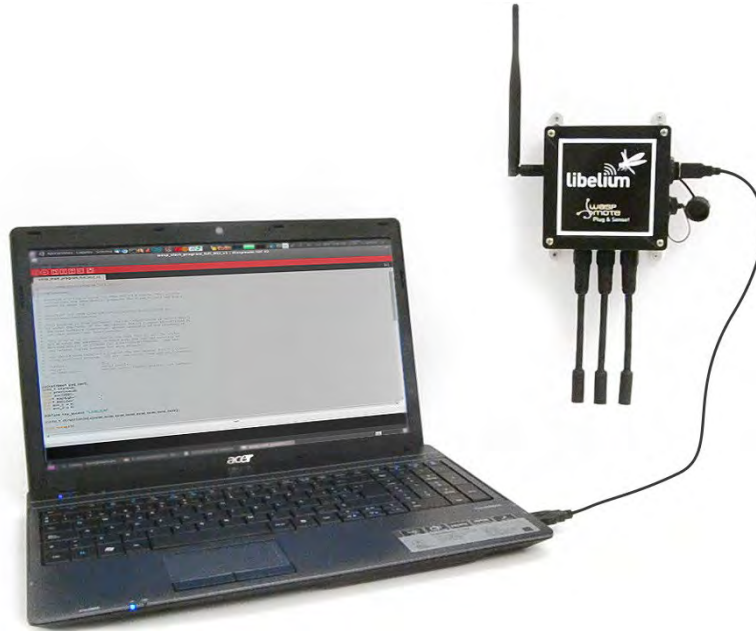

Figure: Programming a node

Over the Air Programming (OTAP) is also possible once the node has been installed (via WiFi or 4G radios). With this technique you can reprogram, wireless, one or more Waspote sensor nodes at the same time by using a laptop and Meshlium.



Figure: Typical OTAP process

### 3.7. Program in minutes

The Programming Cloud Service is an intuitive graphic interface which creates code automatically. The user just needs to fill a web form to obtain binaries for Plug & Sense!. Advanced programming options are available, depending on the license selected.

Check how easy it is to handle the Programming Cloud Service at:

<https://cloud.libelium.com/>

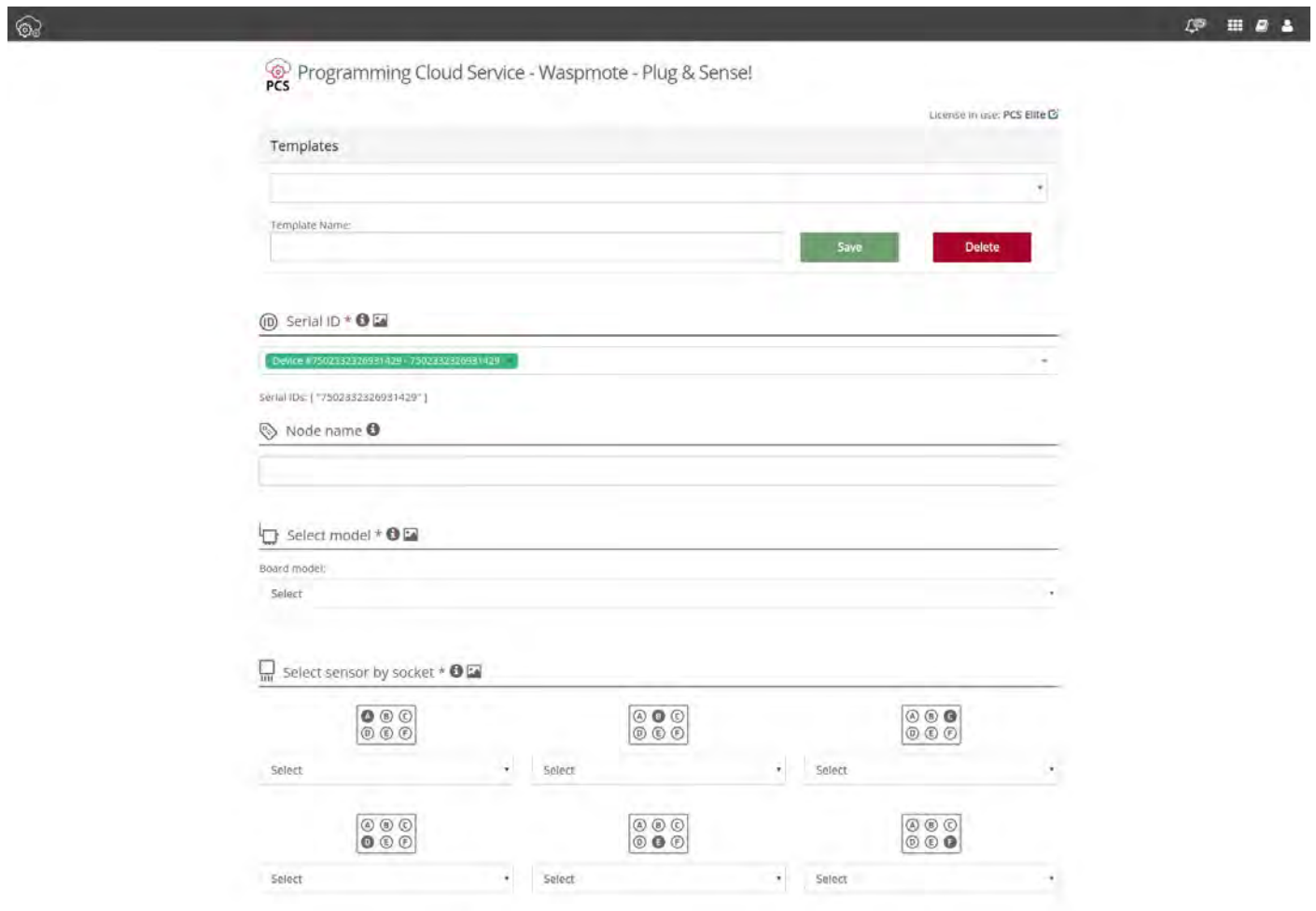

Figure: Programming Cloud Service

### 3.8. Radio interfaces

Radio	Protocol	Frequency bands	Transmission power	Sensitivity	Range*	Certification
XBee-PRO 802.15.4 EU	802.15.4	2.4 GHz	10 dBm	-100 dBm	750 m	CE
XBee-PRO 802.15.4	802.15.4	2.4 GHz	18 dBm	-100 dBm	1600 m	FCC, IC, ANATEL, RCM
XBee 868LP	RF	868 MHz	14 dBm	-106 dBm	8.4 km	CE
XBee 900HP US	RF	900 MHz	24 dBm	-110 dBm	15.5 km	FCC, IC
XBee 900HP BR	RF	900 MHz	24 dBm	-110 dBm	15.5 km	ANATEL
XBee 900HP AU	RF	900 MHz	24 dBm	-110 dBm	15.5 km	RCM
WiFi	WiFi (HTTP(S), FTP, TCP, UDP)	2.4 GHz	17 dBm	-94 dBm	500 m	CE, FCC, IC, ANATEL, RCM
4G EU/BR	4G/3G/2G (HTTP, FTP, TCP, UDP) GPS	800, 850, 900, 1800, 2100, 2600 MHz	4G: class 3 (0.2 W, 23 dBm)	4G: -102 dBm	- km - Typical base station range	CE, ANATEL
4G US	4G/3G/2G (HTTP, FTP, TCP, UDP) GPS	700, 850, 1700, 1900 MHz	4G: class 3 (0.2 W, 23 dBm)	4G: -103 dBm	- km - Typical base station range	FCC, IC, PTCRB, AT&T
4G AU	4G (HTTP, FTP, TCP, UDP)	700, 1800, 2600 MHz	4G: class 3 (0.2 W, 23 dBm)	4G: -102 dBm	- km - Typical base station range	RCM
Sigfox EU	Sigfox	868 MHz	16 dBm	-126 dBm	- km - Typical base station range	CE
Sigfox US	Sigfox	900 MHz	24 dBm	-127 dBm	- km - Typical base station range	FCC, IC
Sigfox AU / APAC / LATAM	Sigfox	900 MHz	24 dBm	-127 dBm	- km - Typical base station range	-
LoRaWAN EU	LoRaWAN	868 MHz	14 dBm	-136 dBm	> 15 km	CE
LoRaWAN US	LoRaWAN	902-928 MHz	18.5 dBm	-136 dBm	> 15 km	FCC, IC
LoRaWAN AU	LoRaWAN	915-928 MHz	18.5 dBm	-136 dBm	> 15 km	-
LoRaWAN IN	LoRaWAN	865-867 MHz	18.5 dBm	-136 dBm	> 15 km	-
LoRaWAN ASIA-PAC / LATAM	LoRaWAN	923 MHz	18.5 dBm	-136 dBm	> 15 km	-

\* Line of sight and Fresnel zone clearance with 5dBi dipole antenna.

### 3.9. Industrial Protocols

Besides the main radio of Waspote Plug & Sense!, it is possible to have an Industrial Protocol module as a secondary communication option. This is offered as an accessory feature.

The available Industrial Protocols are RS-485, Modbus (software layer over RS-485) and CAN Bus. This optional feature is accessible through an additional, dedicated socket on the antenna side of the enclosure.



Figure: Industrial Protocols available on Plug & Sense!

Finally, the user can choose between 2 probes to connect the desired Industrial Protocol: A standard DB9 connector and a waterproof terminal block junction box. These options make the connections on industrial environments or outdoor applications easier.



*Figure: DB9 probe*



*Figure: Terminal box probe*

## 3.10. GPS

Any Plug & Sense! node can incorporate a GPS receiver in order to implement real-time asset tracking applications. The user can also take advantage of this accessory to geolocate data on a map. An external, waterproof antenna is provided; its long cable enables better installation for maximum satellite visibility.



Figure: Plug & Sense! node with GPS receiver

**Chipset:** JN3 (Telit)

**Sensitivity:**

- Acquisition: -147 dBm
- Navigation: -160 dBm
- Tracking: -163 dBm

**Hot start time:** <1 s

**Cold start time:** <35 s

**Positional accuracy error** < 2.5 m

**Speed accuracy** < 0.01 m/s

**EGNOS, WAAS, GAGAN and MSAS capability**

**Antenna:**

- Cable length: 2 m
- Connector: SMA
- Gain: 26 dBi (active)

**Available information:** latitude, longitude, altitude, speed, direction, date&time and ephemeris management

## 3.11. Models

There are some defined configurations of Waspote Plug & Sense! depending on which sensors are going to be used. Waspote Plug & Sense! configurations allow to connect up to six sensor probes at the same time.

Each model takes a different conditioning circuit to enable the sensor integration. For this reason each model allows to connect just its specific sensors.

This section describes each model configuration in detail, showing the sensors which can be used in each case and how to connect them to Waspote. In many cases, the sensor sockets accept the connection of more than one sensor probe. See the compatibility table for each model configuration to choose the best probe combination for the application.

It is very important to remark that each socket is designed only for one specific sensor, so **they are not interchangeable**. Always be sure you connected probes in the right socket, otherwise they can be damaged.

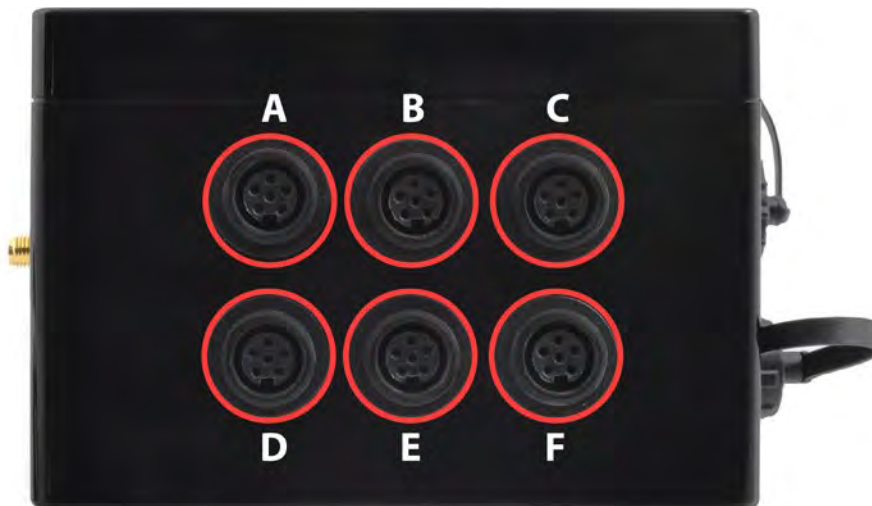

Figure: Identification of sensor sockets



### 3.12. Smart Cities PRO

The main applications for this Waspote Plug & Sense! model are noise maps (monitor in real time the acoustic levels in the streets of a city), air quality, waste management, smart lighting, etc. Refer to [Libelium website](#) for more information.



Figure: Smart Cities PRO Waspote Plug & Sense! model

Sensor sockets are configured as shown in the figure below.

Sensor Socket	Sensor probes allowed for each sensor socket	
	Parameter	Reference
A	Noise level sensor	NLS
	Temperature + Humidity + Pressure	9370-P
	Luminosity (Luxes accuracy)	9325-P
	Ultrasound (distance measurement)	9246-P
B, C, F	Carbon Monoxide (CO) for low concentrations [Calibrated]	9371-LC-P
	Carbon Dioxide (CO <sub>2</sub> ) [Calibrated]	9372-P
	Oxygen (O <sub>2</sub> ) [Calibrated]	9373-P
	Ozone (O <sub>3</sub> ) [Calibrated]	9374-P
	Nitric Oxide (NO) for low concentrations [Calibrated]	9375-LC-P
	Nitric Dioxide (NO <sub>2</sub> ) high accuracy [Calibrated]	9376-HA-P
	Sulfur Dioxide (SO <sub>2</sub> ) high accuracy [Calibrated]	9377-HA-P
	Ammonia (NH <sub>3</sub> ) for low concentrations [Calibrated]	9378-LC-P
	Ammonia (NH <sub>3</sub> ) for high concentrations [Calibrated]	9378-HC-P
	Methane (CH <sub>4</sub> ) and Combustible Gas [Calibrated]	9379-P
	Hydrogen (H <sub>2</sub> ) [Calibrated]	9380-P
	Hydrogen Sulfide (H <sub>2</sub> S) [Calibrated]	9381-P
	Hydrogen Chloride (HCl) [Calibrated]	9382-P
	Hydrogen Cyanide (HCN) [Calibrated]	9383-P
	Phosphine (PH <sub>3</sub> ) [Calibrated]	9384-P
	Ethylene (ETO) [Calibrated]	9385-P
	Chlorine (Cl <sub>2</sub> ) [Calibrated]	9386-P
	Temperature + Humidity + Pressure	9370-P
	Luminosity (Luxes accuracy)	9325-P
	Ultrasound (distance measurement)	9246-P
D	Particle Matter (PM1 / PM2.5 / PM10) - Dust	9387-P
E	Temperature + Humidity + Pressure	9370-P
	Luminosity (Luxes accuracy)	9325-P
	Ultrasound (distance measurement)	9246-P

Figure: Sensor sockets configuration for Smart Cities PRO model

**Note:** For more technical information about each sensor probe go to the [Development section](#) in Libelium website.

Calibrated gas sensors are manufactured once the order has been placed to ensure maximum durability of the calibration feature. The manufacturing process and delivery may take from 4 to 6 weeks. The lifetime of calibrated gas sensors is 6 months working at maximum accuracy. We strongly encourage our customers to buy extra gas sensors to replace the original ones after that time to ensure maximum accuracy and performance.

## 4. Hardware

### 4.1. General description

The purpose of the Waspote Smart Cities PRO board is to extend the monitoring functionalities from indoor environments to outdoor locations, in order to perform IoT projects in Smart Cities and urban environments. Most of the sensors available for Smart Cities PRO are available for the Gases PRO Sensor Board. Also, the Smart Cities PRO board adds support for the Noise Level Sensor.

### 4.2. Specifications

- Weight: 20 g
- Dimensions: 73.5 x 51 x 22 mm (without sensors)
- Temperature range: [-20 °C, 65 °C]

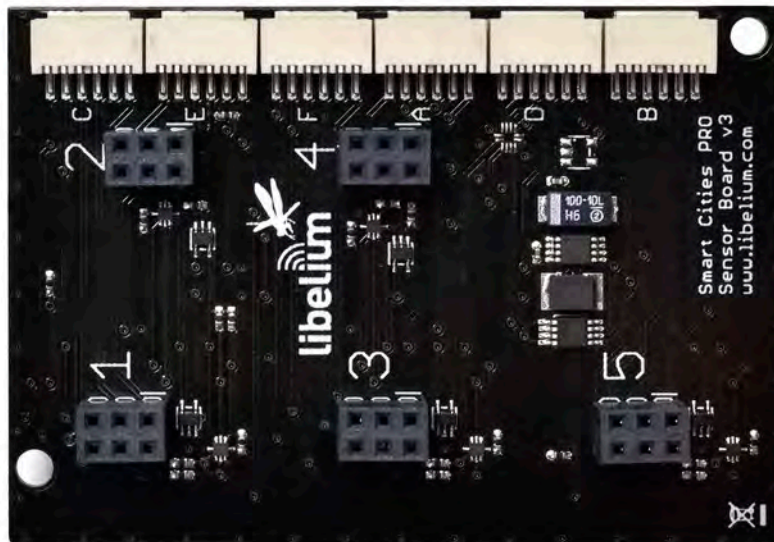

Figure: Top side of the Smart Cities PRO Sensor Board

### 4.3. Electrical characteristics

- Board power voltages: 3.3 V and 5 V
- Sensor power voltages: 3.3 V and 5 V
- Maximum admitted current (continuous): 200 mA
- Maximum admitted current (peak): 400 mA

## 5. Sensors

Many of the sensors available for Smart Cities PRO are actually migrated from the Gases PRO sensor board, where they were integrated initially. For a better understanding of the characteristics of sensors, its calibration and performance, it is highly advised to read the Gases PRO Technical Guide, specially the chapters "Gases PRO sensor board", "Hardware" and "Sensors".

### 5.1. Temperature, Humidity and Pressure Sensor

The BME280 is a digital temperature, humidity and atmospheric pressure sensor developed by Bosch Sensortec.

#### 5.1.1. Specifications

##### Electrical characteristics

Supply voltage: 3.3 V

Sleep current typical: 0.1  $\mu$ A

Sleep current maximum: 0.3  $\mu$ A

##### Temperature sensor

Operational range: -40 ~ +85 °C

Full accuracy range: 0 ~ +65 °C

Accuracy:  $\pm 1$  °C (range 0 °C ~ +65 °C)

Response time: 1.65 seconds (63% response from +30 to +125 °C).

Typical consumption: 1  $\mu$ A measuring

##### Humidity sensor

Measurement range: 0 ~ 100% of relative humidity (for temperatures < 0 °C and > 60 °C see figure below)

Accuracy: <  $\pm 3$ % RH (at 25 °C, range 20 ~ 80%)

Hysteresis:  $\pm 1$ % RH

Operating temperature: -40 ~ +85 °C

Response time (63% of step 90% to 0% or 0% to 90%): 1 second

Typical consumption: 1.8  $\mu$ A measuring

Maximum consumption: 2.8  $\mu$ A measuring



Figure: Temperature, Humidity and Pressure Sensor

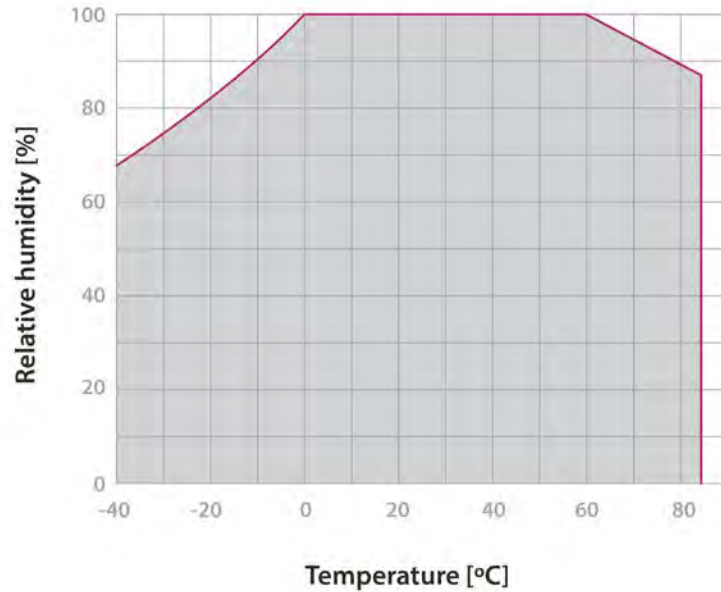

Figure: Humidity sensor operating range

### Pressure sensor

Measurement range: 30 ~ 110 kPa  
 Operational temperature range: -40 ~ +85 °C  
 Full accuracy temperature range: 0 ~ +65 °C  
 Absolute accuracy: ±0.1 kPa (0 ~ 65 °C)  
 Typical consumption: 2.8 µA measuring  
 Maximum consumption: 4.2 µA measuring

## 5.1.2. Measurement process

The BME280 is as combined digital humidity, pressure and temperature sensor based on proven sensing principles. The humidity sensor provides an extremely fast response time for fast context awareness applications and high overall accuracy over a wide temperature range.

The pressure sensor is an absolute barometric pressure sensor with extremely high accuracy and resolution and drastically lower noise.

The integrated temperature sensor has been optimized for lowest noise and highest resolution.

Its output is used for temperature compensation of the pressure and humidity sensors and can also be used for estimation of the ambient temperature.

When the sensor is disabled, current consumption drops to 0.1 µA.

You can find a complete example code for reading the BME280 sensor in the following link:

<http://www.libelium.com/development/waspmote/examples/scp-v30-05-temperature-humidity-and-pressure-sensor>

### 5.1.3. Socket

This sensor can be connected in sockets 1, 2, 3, 4 and 5 in Wasp mote OEM and sockets A, B, C, E and F in Plug & Sense!.

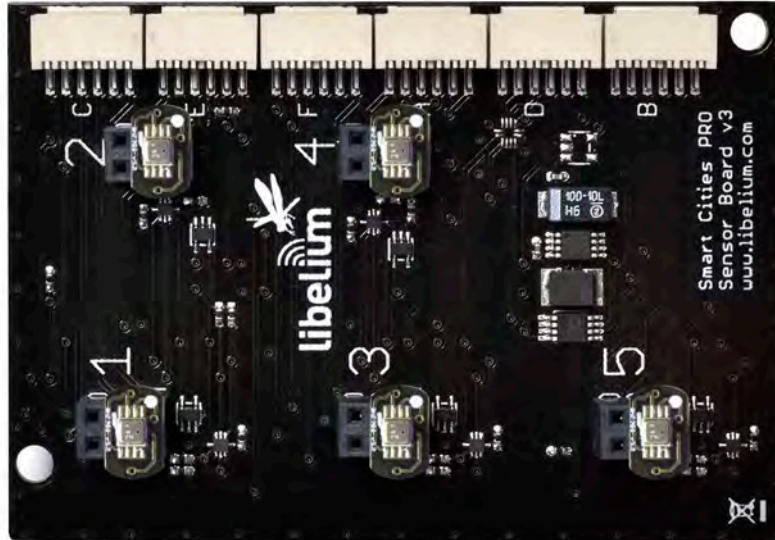

Figure: Temperature, Humidity and Pressure Sensors in sockets 1, 2, 3, 4 and 5

In the image above we can see highlighted the four pins of the terminal block where the sensor must be connected to the board. The white dot on the luxes board, must match the mark of the Smart Cities PRO Sensor Board. Please mind that each socket has 3 rows, but only 2 are used for that sensor, because it only has 2x2 pins. A bad connection can cause malfunction or even hardware damage.

## 5.2. Ultrasound sensor probe (MaxSonar® from MaxBotix™)

### 5.2.1. Specifications

#### I2CXL-MaxSonar®-MB7040™

- Operation frequency:** 42 kHz
- Maximum detection distance:** 765 cm
- Interface:** Digital bus
- Power supply:** 3.3 V
- Consumption (average):** 2.1 mA
- Consumption (peak):** 50 mA
- Usage:** Indoors and outdoors (IP-67)



Figure: Ultrasonic I2CXL-MaxSonar®-MB7040 from MaxBotix™ sensor

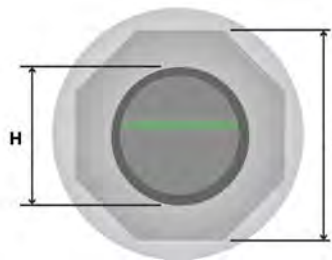
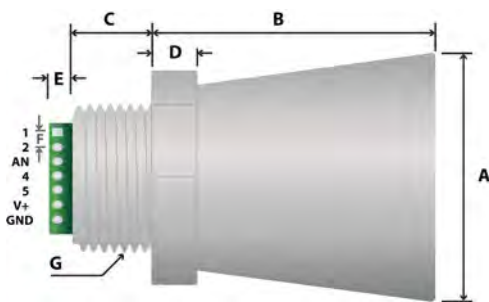

A	1.72" dia.	43.8 mm dia.
B	2.00"	50.7 mm
C	0.58"	14.4 mm
D	0.31"	7.9 mm
E	0.18"	4.6 mm
F	0.1"	2.54 mm
G	3/4" National Pipe Thread Straight	
H	1.032" dia.	26.2 dia.
I	1.37"	34.8 mm
<b>weight: 1.76 oz. ; 50 grams</b>		

Figure: Ultrasonic I2CXL-MaxSonar®-MB7040 sensor dimensions

In the figure below we can see a diagram of the detection range of the sensor developed using different detection patterns (a 0.63 cm diameter dowel for diagram A, a 2.54 cm diameter dowel for diagram B, an 8.25cm diameter rod for diagram C and a 28 cm wide board for diagram D):

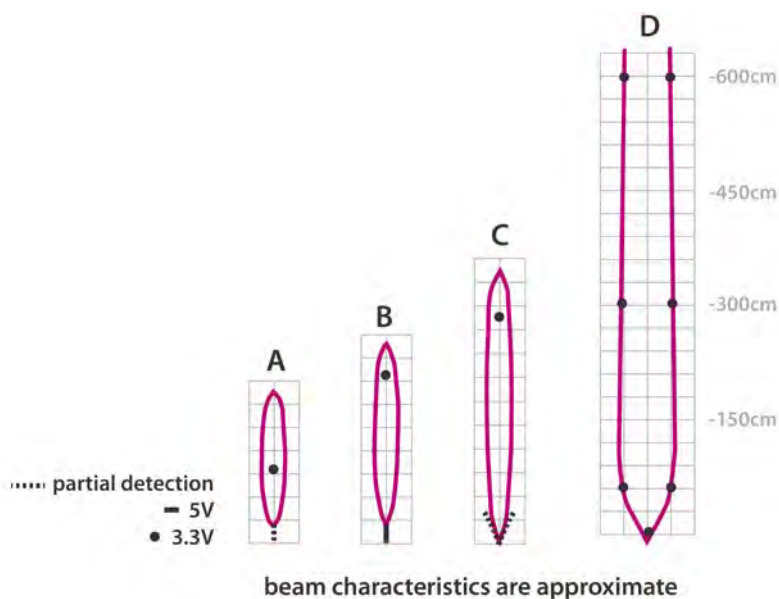

Figure: Diagram of the sensor beam extracted from the data sheet of the XL-MaxSonar®-WRA1™ sensor from MaxBotix

**I2CXL-MaxSonar®-MB1202™:**

- **Operation frequency:** 42 kHz
- **Maximum detection distance:** 765 cm
- **Consumption (average):** 2 mA
- **Consumption (peak):** 50 mA
- **Usage:** Indoors only



Figure: Ultrasonic I2CXL-MaxSonar®- MB1202 from MaxBotix™ Sensor

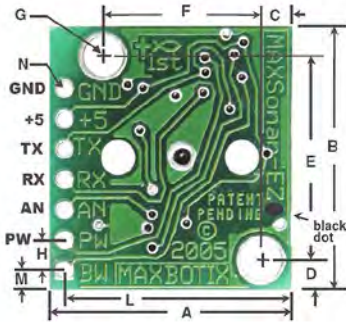

A	0.785"	19.9 mm	H	0.100"	2.54 mm
B	0.870"	22.1 mm	J	0.645"	16.4 mm
C	0.100"	2.54 mm	K	0.610"	15.5 mm
D	0.100"	2.54 mm	L	0.735"	18.7 mm
E	0.670"	17.0 mm	M	0.065"	1.7 mm
F	0.510"	12.6 mm	N	0.038" dia.	1.0 mm dia.
G	0.124" dia.	3.1 mm dia.	weight: 4.3 grams		

Figure: Ultrasonic I2CXL-MaxSonar®-MB1202 Sensor dimensions

In the figure below we can see a diagram of the detection range of the sensor developed using different detection patterns (a 0.63 cm diameter dowel for diagram A, a 2.54 cm diameter dowel for diagram B, an 8.25 cm diameter rod for diagram C and a 28 cm wide board for diagram D):

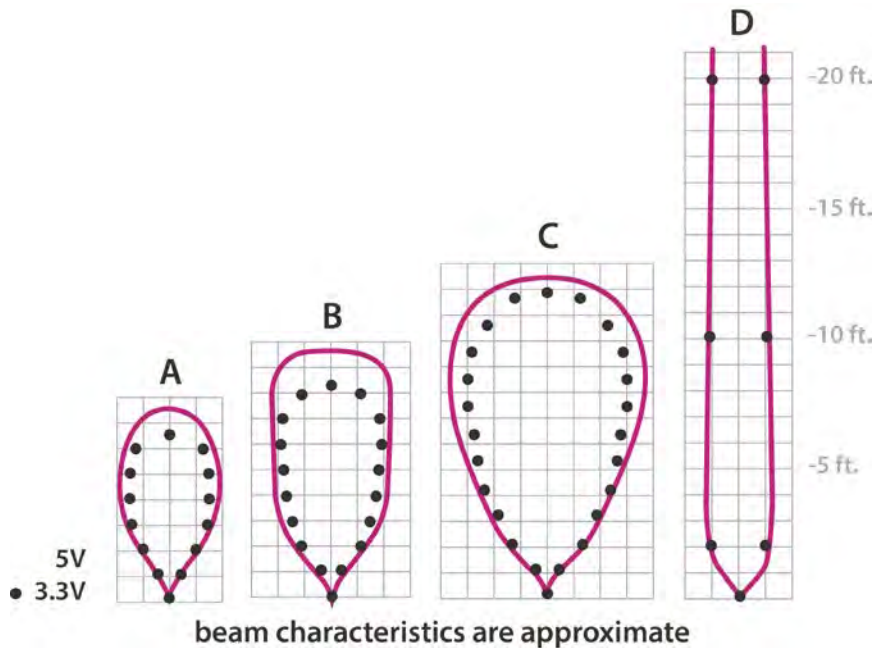

Figure: Diagram of the sensor beam extracted from the data sheet of the Ultrasonic I2CXL-MaxSonar®-MB1202 sensor from MaxBotix



### 5.2.2. Measurement Process

The MaxSonar® sensors from MaxBotix can be connected through the digital bus interface.

In the next figure, we can see a drawing of two example applications for the ultrasonic sensors, such as liquid level monitoring or presence detection.

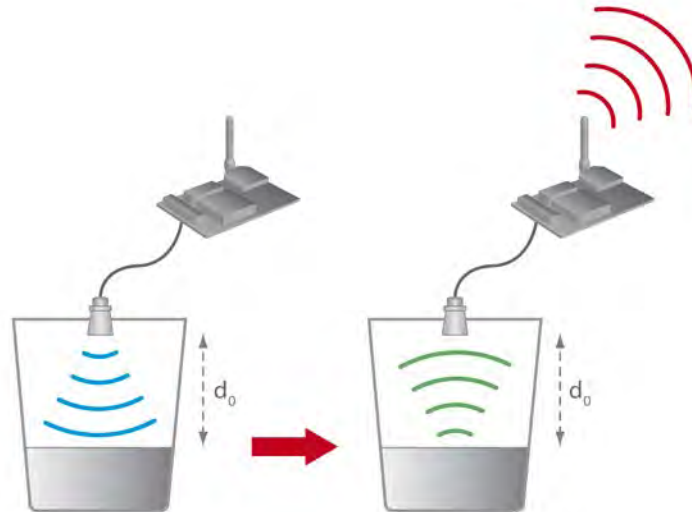

Figure: Examples of application for the MaxSonar® sensors

The MB7040 sensor is endowed with an IP-67 casing, so it can be used in outdoors applications, such as liquid level monitoring in storage tanks.

You can find a complete example code for reading the distance in the following link:  
[www.libelium.com/development/waspmote/examples/scp-v30-06-ultrasound-sensor](http://www.libelium.com/development/waspmote/examples/scp-v30-06-ultrasound-sensor)

### 5.2.3. Socket

These sensors can be connected in socket 1, 2, 3, 4 and 5 in Waspmote OEM and sockets A, B, C, E and F in Plug & Sense!.

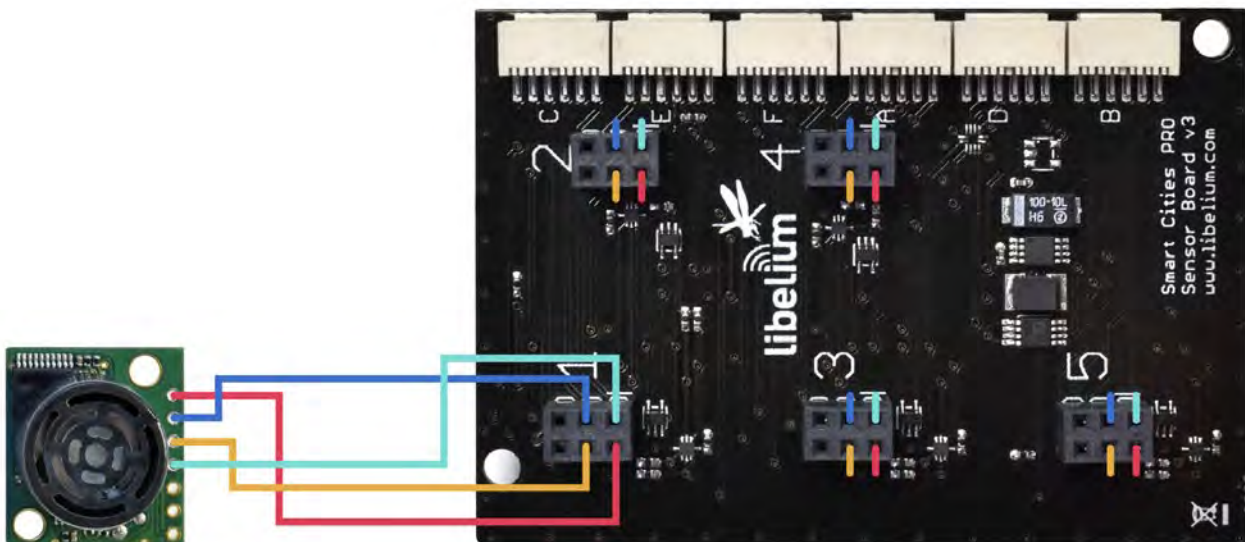

Figure: Images of the sockets for connecting the MaxSonar® Sensors

## 5.3. Luminosity (Luxes accuracy) Sensor

### 5.3.1. Specifications

#### Electrical characteristics

Dynamic range: 0.1 to 40000 lux

Spectral range: 300 ~ 1100 nm

Voltage range: 2.7 ~ 3.6 V

Supply current typical: 0.24 mA

Sleep current maximum: 0.3  $\mu$ A

Operating temperature: -30 ~ 70 °C



Figure: Image of the Luminosity Sensor

### 5.3.2. Measurement process

This is a light-to-digital converter that transforms light intensity into a digital signal output. This device combines one broadband photo-diode (visible plus infrared) and one infrared-responding photo-diode on a single CMOS integrated circuit capable of providing a near-photopic response over an effective 20-bit dynamic range (16-bit resolution). Two integrating ADCs convert the photo-diode currents to a digital output that represents the irradiance measured on each channel. This digital output in lux is derived using an empirical formula to approximate the human eye response.

You can find a complete example code for reading the luminosity in the following link:

[www.libelium.com/development/waspmote/examples/scp-v30-07-luxes-sensor](http://www.libelium.com/development/waspmote/examples/scp-v30-07-luxes-sensor)

### 5.3.3. Socket

This sensor can be connected in socket 1, 2, 3, 4 and 5 in Waspmote OEM and sockets A, B, C, E and F in Plug & Sense!

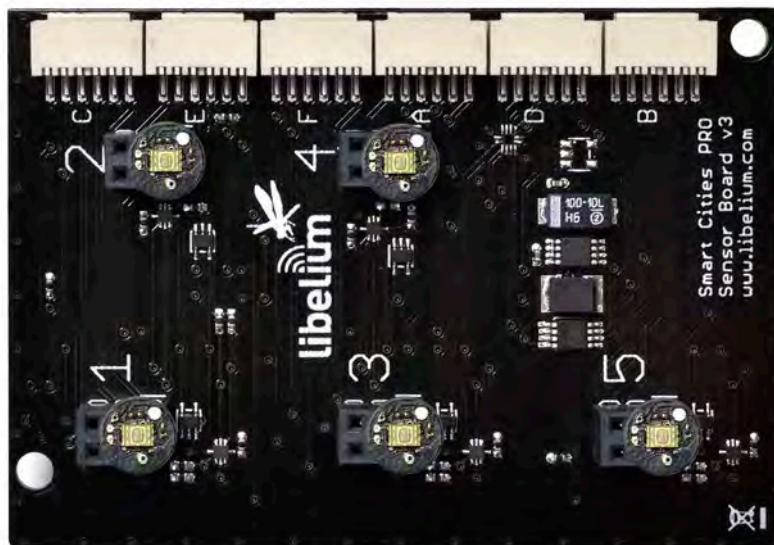

Figure: Luxes sensors connected in sockets 1, 2, 3, 4 and 5

In the image above we can see highlighted the four pins of the terminal block where the sensor must be connected to the board. The white dot on the luxes board, must match the mark of the Smart Cities PRO Sensor Board. Please mind that each socket has 3 rows, but only 2 are used for that sensor, because it only has 2x2 pins. A bad connection can cause malfunction or even hardware damage.

## 5.4. Particle Matter (PM1 / PM2.5 / PM10) - Dust Sensor

**Note:** Since February 2019, the OPC-N3 sensor is supplied instead of the OPC-N2. The OPC-N3 has taken the success of the older OPC-N2 unit and has improved it further. With the same dimensions and power/ interface as the N2, the OPC-N3 now measures from 0.35  $\mu\text{m}$  to 40  $\mu\text{m}$ , sorting into 24 size bins. Features include improved aerodynamics with reduction of particle deposition, better low end performance, extended upper size measurements and high/low flow rate digital selection. The OPC-N3 can measure from clean rooms to pollution levels to 2,000  $\mu\text{g}/\text{m}^3$  with the unique feature of being able to size classify pollen.

### 5.4.1. Specifications

#### Specifications

**Sensor:** OPC-N3

#### Performance Characteristics

**Laser classification:** Class 1 as enclosed housing

**Particle range ( $\mu\text{m}$ ):** 0.35 to 40 spherical equivalent size (based on RI of 1.5)

**Size categorization (standard):** 24 software bins

**Sampling interval (seconds):** 1 to 30 histogram period

**Total flow rate:** 5.5 L/min

**Sample flow rate:** 280 mL/min

**Max particle count rate:** 10000 particles/second

**Max coincidence probability:** 0.84% at 10,000,000 particles/L  
0.24% at 500 particles/L

#### Power Characteristics

**Measurement mode (laser and fan on):** 270 mA @ 5 Volts (typical)

**Voltage Range:** 4.8 to 5.2 V DC

#### Operation Conditions

**Temperature Range:** -10  $^{\circ}\text{C}$  to 50  $^{\circ}\text{C}$

**Operating Humidity:** 0 to 99% RH non-condensing



*Figure: Image of the Particle Matter sensor, encapsulated*

This sensor has a high current consumption. It is very important to turn on the sensor to perform a measure and then, turn it off to save battery.

Dust, dirt or pollen may be accumulated inside the dust sensor structure, especially when the sensor is close to possible solid particle sources: parks, construction works, deserts. That is why it is highly recommended to perform maintenance/cleaning tasks in order to have accurate measures. This maintenance/cleaning frequency may vary depending on the environment conditions or amount of obstructing dust. In clean atmospheres or with low particle concentrations, the maintenance/cleaning period will be longer than a place with a high particle concentrations.

DO NOT remove the external housing: this not only ensures the required airflow but also protects the user from the laser light. Removal of the casing may expose the user to Class 3B laser radiation. You must avoid exposure to the laser beam. Do not use if the outer casing is damaged. Return to Libelium. Removal of the external housing exposes the OPC circuitry which contains components that are sensitive to static discharge damage.

**Note:** The Particle Matter (PM1 / PM2.5 / PM10) – Dust Sensor is available only for the Plug & Sense! line.

### 5.4.2. Particle matter: the parameter

Particle matter is composed of small solid or liquid particles floating in the air. The origin of these particles can be the industrial activity, exhaust fumes from diesel motors, building heating, pollen, etc. These tiny particles enter our bodies when we breathe. High concentrations of particle matter can be harmful for humans or animals, leading to respiratory and coronary diseases, and even lung cancer. That is why this is a key parameter for the Air Quality Index.

Some examples:

- Cat allergens: 0.1-5  $\mu\text{m}$
- Pollen: 10-100  $\mu\text{m}$
- Germs: 0.5-10  $\mu\text{m}$
- Oil smoke: 1-10  $\mu\text{m}$
- Cement dust: 5-100  $\mu\text{m}$
- Tobacco smoke: 0.01-1  $\mu\text{m}$

The smaller the particles are, the more dangerous, because they can penetrate more in our lungs. Many times, particles are classified:

- PM1: Mass (in  $\mu\text{g}$ ) of all particles smaller than 1  $\mu\text{m}$ , in 1  $\text{m}^3$
- PM2.5: Mass (in  $\mu\text{g}$ ) of all particles smaller than 2.5  $\mu\text{m}$ , in 1  $\text{m}^3$
- PM10: Mass (in  $\mu\text{g}$ ) of all particles smaller than 10  $\mu\text{m}$ , in 1  $\text{m}^3$

Many countries and health organizations have studied the effect of the particle matter in humans, and they have set maximum thresholds. As a reference, the maximum allowed concentrations are about 20  $\mu\text{g}/\text{m}^3$  for PM2.5 and about 50  $\mu\text{g}/\text{m}^3$  for PM10.

### 5.4.3. Measurement process

Like conventional optical particle counters, the OPC-N3 measures the light scattered by individual particles carried in a sample air stream through a laser beam. These measurements are used to determine the particle size (related to the intensity of light scattered via a calibration based on Mie scattering theory) and particle number concentration. Particle mass loading- PM2.5 or PM10, are then calculated from the particle size spectra and concentration data, assuming density and refractive index. To generate the air stream, the OPC-N3 uses only a miniature low-power fan.

The OPC-N3 classifies each particle size, at rates up to ~10,000 particle per second, adding the particle diameter to one of 24 "bins" covering the size range from ~0.35 to 40  $\mu\text{m}$ . The resulting particle size histograms can be evaluated over user-defined sampling times from 1 to 30 seconds duration, the histogram data being transmitted along with other diagnostic and environmental data (air temperature and air humidity). When the histogram is read, the variables in the library are updated automatically. See the API section to know how to manage and read this sensor

You can find a complete example code for reading the Particle Matter Sensor in the following link:  
<http://www.libelium.com/development/waspote/examples/scp-v30-04-particle-matter-sensor>

## 5.5. Noise / Sound Level Sensor

### 5.5.1. Specifications of the Sound Level Sensor probe

- **Target parameter:** LeqA
- **Microphone sensitivity:** 12.7 mV / Pa
- **Range of the sensor:** 50 dBA to 100 dBA
- **Accuracy:** +/-0.5dBA (1KHz)
- **Frequency range:** 20 Hz – 20 kHz
- Omni-directional microphone
- **A-weighting** measure
- Sound pressure level measurement (no weighting filter)
- **FAST** mode (125 ms) and **SLOW** mode (1 second), software configurable

### 5.5.2. Specifications of the enclosure

- **Material:** polycarbonate
- **Sealing:** polyurethane
- **Cover screws:** stainless steel
- **Ingress protection:** IP65
- **Impact resistance:** IK08
- **Rated insulation voltage AC:** 690 V
- **Rated insulation voltage DC:** 1000 V
- **Heavy metals-free**
- **Weatherproof:** true - nach UL 746 C
- **Ambient temperature (min.):** -10 °C
- **Ambient temperature (max.):** 50 °C
- **Approximated weight:** 800 g

### 5.5.3. Sound pressure level measurement

The sound pressure level or acoustic pressure level is a measure of the effective pressure of a sound relative to a reference value, normally referenced to pressure in air (20 µPa), which is considered as the threshold of the human hearing. The expression of the sound pressure level is defined by:

$$L_p = 20 \times \log\left(\frac{P_1}{P_0}\right)$$

Figure: Sound pressure level expression



Figure: Noise / Sound Level Sensor

Where  $p$  is the root mean square sound pressure and  $p_0$  is the reference sound pressure (20  $\mu\text{Pa}$ ). The next table shows some examples of different sound pressure measurements:

Sound sources examples	Sound pressure level (dB)	Sound pressure (Pa = N/m <sup>2</sup> )	Sound intensity (W/m <sup>2</sup> )
Threshold of pain	130	63.2	10
Threshold of discomfort	120	20	1
Airport	110	6.3	0.01
Factory	100	2	0.001
Heavy traffic	90	0.63	0.0001
Hair dryer	80	0.2	0.00001
Restaurant	70	0.063	0.000001
Conversation	60	0.02	0.0000001
Background noise	50	0.0063	0.00000001
Refrigerator	40	0.002	0.000000001
Library	30	0.00063	0.0000000001
Recording studio	20	0.0002	0.00000000001
Anechoic chamber	10	0.000063	0.000000000001
Threshold of hearing	0	0.00002	0.0000000000001

#### 5.5.4. Equivalent continuous sound level

The sound pressure level parameter, explained in the previous section, is not much used in noise measurements. Instead, an average value called  $L_{eq}$ , is used. Equivalent Continuous Sound Level ( $L_{eq}$ ) is the average of the sound pressure level during a period of time. This value is very used when the noise level is varying quickly. Below the equation to calculate the  $L_{eq}$  value in decibels.

$$L_{eq} = 20 \times \log \left[ \left( \frac{1}{t_2 - t_1} \right) \int_{t_1}^{t_2} \left( \frac{p_1}{p_0} \right) dt \right]$$

The  $L_{eq}$  is the most used parameter by most countries for measuring the exposure to noise levels and earing damage risk. A better approximation to the human ear response is the  $LA_{eq}$  (equivalent continuous A-weighted sound pressure level). The A-weighting filter is described in the next section of this guide.

#### 5.5.5. The A-weighting

The A-weighting is the most used curve of the family of curves defined by the IEC 61672 standard. It is very used for measuring environmental and industrial noise, due to the fact that the curve follows the frequency sensitivity of the human ear. Noise measurements made with the A-weighting scale are designated dBA. The A-weighting also predicts quite well the damage risk of the ear. The next graph shows the response of the A-weighting across the frequency range 10 Hz – 20 kHz.

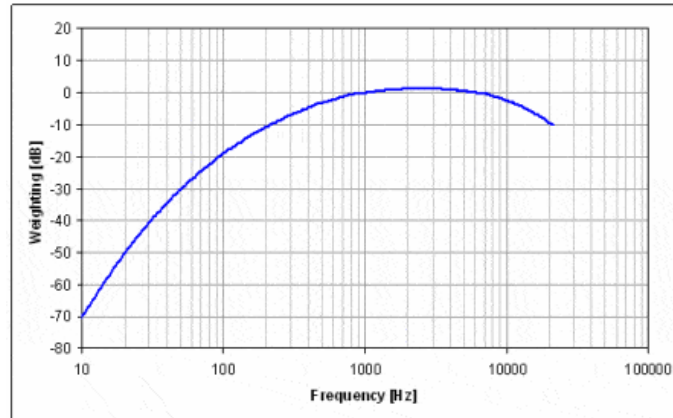

Figure: Graph of the A-weighting curve

### 5.5.6. International standard IEC 61672-1:2013

The new Noise / Sound Level Sensor has been designed following the specifications of the IEC 61672 standard for sound meters. Specifically with an accuracy of  $\pm 2$  dBA similar to the Class 2 type devices. The value given is the LeqA (Equivalent continuous sound level, with A weighting) that allows to calculate the average sound pressure level during a period of time. Leq is often described as the average noise level during a noise measurement and it is the magnitude used for many regulations of noise control at work places and the street.

### 5.5.7. Measurement process

As mentioned previously, the Sound Level Sensor can only be used in combination with a Plug & Sense! Smart Cities PRO device. Once the sensor is connected following the previous steps, the Waspote Plug & Sense! unit must be programmed for reading the sound pressure values.

You can find a complete example code for reading the temperature sensor in the following link:  
<http://www.libelium.com/development/waspote/examples/scp-v30-08-noise-level-sensorg>

### 5.5.8. Calibration Tests

In order to ensure the high quality of the Noise / Sound Level Sensor, each device is verified in an independent test laboratory.

Tests are performed inside an isolated anechoic chamber. The sound sensor probes are exposed to 5 different levels of white noise, created by a specialized sound generator and a cutting-edge, omni-directional speaker: 55, 65, 75, 85 and 95 dBA. The exact level is confirmed by the technician with a certified IEC 61672 soundmeter, placed at the same distance from the sound source than the 16 sensors. For each noise level, the output of each one of the 16 sensors is captured by a software system.



After those tests, an official test report is issued by the laboratory for every Noise / Sound Level Sensor, so the customer can verify the accuracy in dBA at different frequencies for each sound level probe. See below an example of this document.

Libelium ships every Noise / Sound Level Sensor with its test report. It takes some weeks to the laboratory to issue the test reports, so a Noise / Sound Level Sensor may be sent without the test report; in this case, the customer can to ask for the test report to their Sales agent.

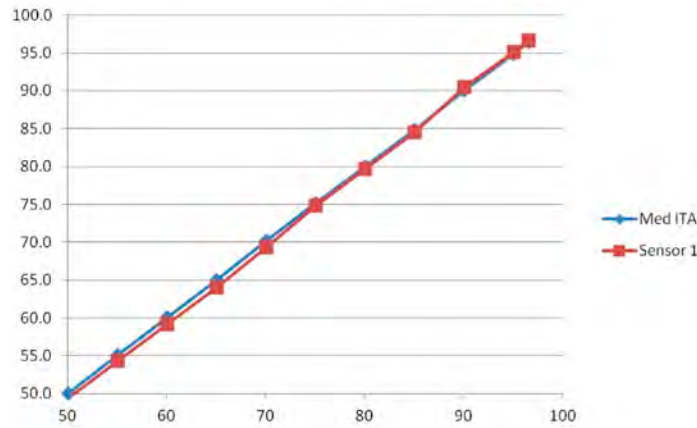

Figure: Example of test report obtained in the laboratory

## Sound Level Tests

*Test Report*  
**Número:** C/183107110  
*Number*

---

**ARAGON INSTITUTE OF TECHNOLOGY**  
TESTING AND CALIBRATION LABORATORY

**ITAINNOVA**  
INSTITUTO TECNOLÓGICO DE ARAGÓN

Next table shows the results obtained in tests with the sound level sensor probe labeled as: ID-0X0569872

Target reference level (dBA)	Real level, measured by certified soundmeter (dBA)	Measured by sound sensor; ID-0X0569872 (dBA)	Difference (dBA)
55	54.9	54.2	0.7
65	65.9	65.5	0.4
75	75.2	75	0.2
85	85.1	84.8	0.3
95	95.1	94.7	0.4



### 5.5.9. Mounting the Noise / Sound Level Sensor and supplying power

**Important:** The Noise Level Sensor has been designed to be used with the Waspote Plug & Sense! Smart Cities PRO and it cannot be used independently. This sensor cannot be used on a Waspote OEM with a Smart Cities PRO board, for example.

The Sound Level Sensor consists of the next items shown in the figure below:



Figure: Noise Level Sensor items: 1 Noise Level Sensor. 2 Noise Level Sensor enclosure. 3 Data cable. 4 Power supply cable. 5 Protection cover

The images below show the different sockets of the Noise Level Sensor.



Figure: Identification of the connectors



Figure: Power supply connector



Figure: Noise Level Sensor probe

To connect the Sound Level Sensor probe to the enclosure, it should be taken into account that the sensor probe connector has only one matching position. The user should align the sensor probe connector looking at the little notch of the connector (see image below). Notice that the sensor connector is male-type and the enclosure sensor connector is female-type.



Figure: Detail of the sensor probe connector

Besides, there is a locking nut which should be screwed till the connector is completely fixed to the enclosure.



Figure: Connecting the sensor probe to the enclosure

After connecting the sensor, connect the the power supply cable to the USB connector, as shown in the picture below and the Noise Level Sensor will power up. Then, connect one end of data cable to the Sound Level Sensor and the other one to the associated Plug & Sense! Smart Cities PRO device.

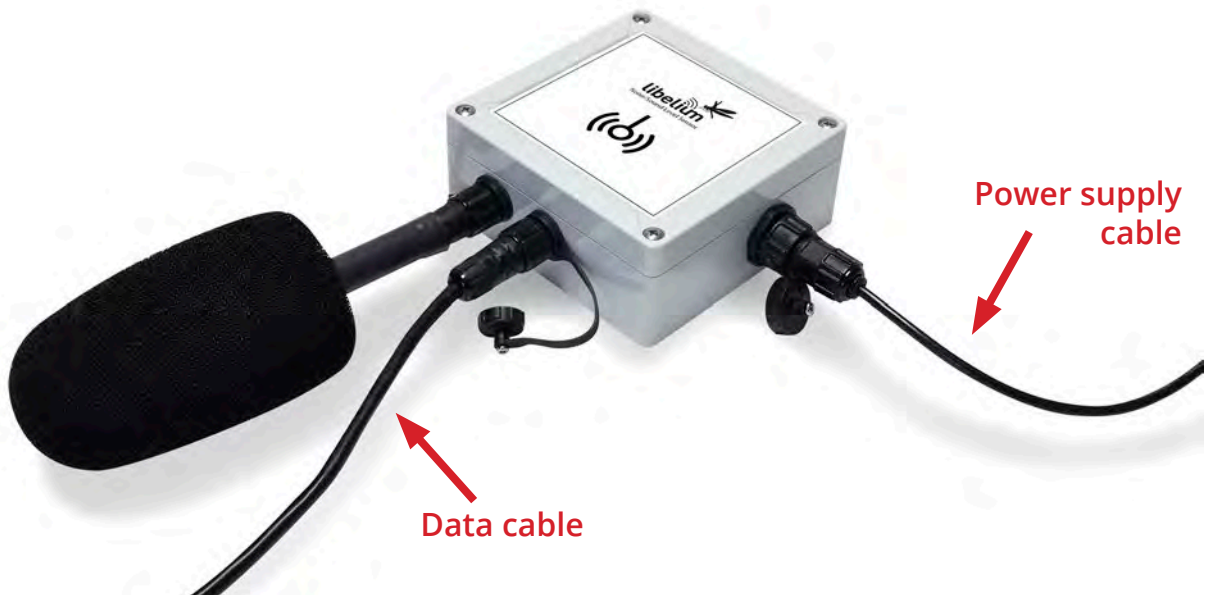

Figure: Connecting the data cable and the power supply cable to the Noise Level Sensor



Figure: Connecting the data cable to the associated Plug & Sense! Smart Cities device

Finally, the Noise Level Sensor can be installed outdoors in a streetlight or directly on a wall. The protection cover should be placed like the pictures below, to protect the Sound Level Sensor probe from the rain.



Figure: Installing the Noise Level Sensor on a wall

Notice that the power supply cable has a waterproof end, suitable for outdoor applications. But, on the other side, it has a non-waterproof end thought to be connected to a USB charger (AC/DC, 5 V output). Bear in mind that this end is not waterproof so it cannot be used outdoors. Please protect it accordingly.

A typical application is to power a node placed on the facade of a building; the power supply cables go indoors through a nearby window and the USB ends remain indoors, connected to a wall adapter. Many lampposts also have a 220 V output inside.

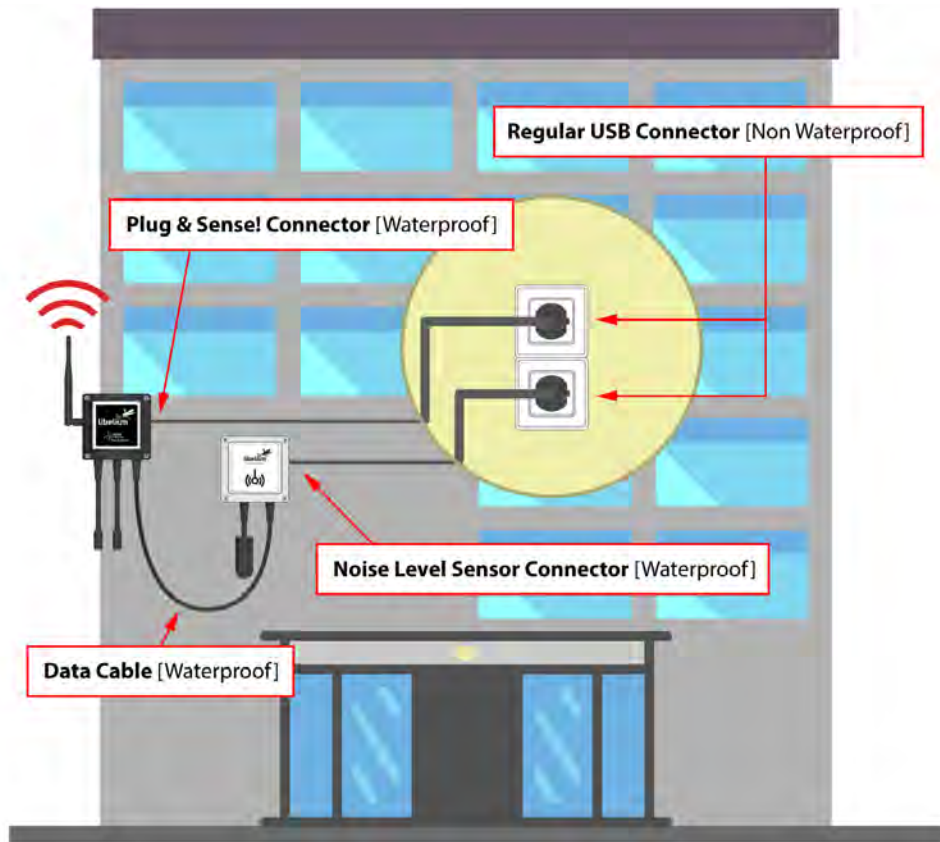

Figure: Typical installation of the Noise Level Sensor

## 5.6. Carbon Monoxide (CO) Gas Sensor for high concentrations [Calibrated]

### 5.6.1. Specifications

**Gas:** CO

**Sensor:** 4-CO-500

#### Performance Characteristics

**Nominal Range:** 0 to 500 ppm

**Maximum Overload:** 2000 ppm

**Long Term Output Drift:** < 2% signal/month

**Response Time (T90):** ≤ 30 seconds

**Sensitivity:** 70 ± 15 nA/ppm

**Accuracy:** as good as ±1 ppm\* (ideal conditions)

#### Operation Conditions

**Temperature Range:** -20 °C to 50 °C

**Operating Humidity:** 15 to 90% RH non-condensing

**Pressure Range:** 90 to 110 kPa

**Storage Temperature:** 0 °C to 20 °C

**Expected Operating Life:** 5 years in air

#### **Sockets for Waspote OEM:**

- SOCKET\_1
- SOCKET\_3
- SOCKET\_5

#### **Sockets for Plug & Sense!:**

- SOCKET\_B
- SOCKET\_C
- SOCKET\_F

**Average consumption:** less than 1 mA

\* Accuracy values are only given for the **optimum case**. See the "Calibration" chapter in the Gases PRO Technical Guide for more detail.

The electrochemical sensors must be always powered on in order to get optimum measurements. This implies a power consumption, however it improves the performance of the sensor. This should also be applied when entering sleep modes so the sensor is not powered off selecting the proper sleep option.

Calibrated gas sensors are manufactured once the order has been placed to ensure maximum durability of the calibration feature. The manufacturing process and delivery may take from 4 to 6 weeks. The lifetime of calibrated gas sensors is 6 months working at maximum accuracy. We strongly encourage our customers to buy extra gas sensors to replace the original ones after that time to ensure maximum accuracy and performance.



Figure: Image of the Carbon Monoxide Sensor for high concentrations mounted on its AFE module

## 5.6.2. Cross-sensitivity data

Gas	Formula	Concentration (ppm)	Output Signal (ppm CO equivalent)
Hydrogen Sulfide	H <sub>2</sub> S	24	0
Sulfur Dioxide	SO <sub>2</sub>	5	0
Chlorine	Cl <sub>2</sub>	10	0-1
Nitric Oxide	O <sub>2</sub>	25	0
Nitric Dioxide	NO <sub>2</sub>	5	0
Hydrogen	H <sub>2</sub>	100	40
Ethylene	C <sub>2</sub> H <sub>4</sub>	100	16

Figure: Cross-sensitivity data for the CO Sensor for high concentrations

You can find a complete example code for reading the CO Sensor for high concentrations in the following link: [www.libelium.com/development/waspmote/examples/scp-v30-01-electrochemical-gas-sensors](http://www.libelium.com/development/waspmote/examples/scp-v30-01-electrochemical-gas-sensors)

## 5.7. Carbon Monoxide (CO) Gas Sensor for low concentrations [Calibrated]

### 5.7.1. Specifications

**Gas:** CO

**Sensor:** CO-A4

#### Performance Characteristics

**Nominal Range:** 0 to 25 ppm

**Maximum Overload:** 2000 ppm

**Long Term Sensitivity Drift:** < 10% change/year in lab air, monthly test

**Long Term zero Drift:** <  $\pm 100$  ppb equivalent change/year in lab air

**Response Time (T90):**  $\leq 20$  seconds

**Sensitivity:** 220 to 375 nA/ppm

**Accuracy:** as good as  $\pm 0.1$  ppm\* (ideal conditions)

**H2S filter capacity:** 250000 ppm·hrs

#### Operation Conditions

**Temperature Range:** -30 °C to 50 °C

**Operating Humidity:** 15 to 90% RH non-condensing

**Pressure Range:** 80 to 120 kPa

**Storage Temperature:** 0 °C to 20 °C

**Expected Operating Life:** 3 years in air

#### **Sockets for Waspote OEM:**

- SOCKET\_1
- SOCKET\_3
- SOCKET\_5

#### **Sockets for Plug & Sense!:**

- SOCKET\_B
- SOCKET\_C
- SOCKET\_F

**Average consumption:** less than 1 mA

\* Accuracy values are only given for the **optimum case**. See the "Calibration" chapter in the Gases PRO Technical Guide for more detail.

The electrochemical sensors must be always powered on in order to get optimum measurements. This implies a power consumption, however it improves the performance of the sensor. This should also be applied when entering sleep modes so the sensor is not powered off selecting the proper sleep option.

Calibrated gas sensors are manufactured once the order has been placed to ensure maximum durability of the calibration feature. The manufacturing process and delivery may take from 4 to 6 weeks. The lifetime of calibrated gas sensors is 6 months working at maximum accuracy. We strongly encourage our customers to buy extra gas sensors to replace the original ones after that time to ensure maximum accuracy and performance.



Figure: Image of the Carbon Monoxide Sensor for low concentrations mounted on its AFE module



## 5.7.2. Cross-sensitivity data

Gas	Formula	Concentration (ppm)	Output signal (ppm CO equivalent)
Hydrogen Sulfide	H <sub>2</sub> S	5	< 0.1
Nitric Dioxide	NO <sub>2</sub>	5	< -2
Chlorine	Cl <sub>2</sub>	5	< 0.1
Nitric Oxide	NO	5	< -2
Sulfur Dioxide	SO <sub>2</sub>	5	< 0.1
Hydrogen	H <sub>2</sub>	100	< 10
Ethylene	C <sub>2</sub> H <sub>4</sub>	100	< 0.5
Ammonia	NH <sub>3</sub>	20	< 0.1

Figure: Cross-sensitivity data for the CO Sensor for low concentrations

You can find a complete example code for reading the CO Sensor for low concentrations in the following link: [www.libelium.com/development/waspmote/examples/scp-v30-01-electrochemical-gas-sensors](http://www.libelium.com/development/waspmote/examples/scp-v30-01-electrochemical-gas-sensors)

## 5.8. Carbon Dioxide (CO<sub>2</sub>) Gas Sensor [Calibrated]

### 5.8.1. Specifications

**Gas:** CO<sub>2</sub>

**Sensor:** NE20-CO2P-NCVSP

#### Performance Characteristics

**Nominal Range:** 0 to 5000 ppm

**Long Term Output Drift:** < ± 250 ppm/year

**Warm up time:** 60 seconds @ 25 °C

At least 30 min for full specification @ 25 °C

**Response Time (T90):** ≤ 60 seconds

**Resolution:** 25 ppm

**Accuracy:** as good as ±50 ppm\*, from 0 to 2500 ppm range (ideal conditions)

as good as ±200 ppm\*, from 2500 to 5000 ppm range (ideal conditions)

#### Operation Conditions

**Temperature Range:** -40 °C to 60 °C

**Operating Humidity:** 0 to 95%RH non-condensing

**Storage Temperature:** -40 °C to 85 °C

**MTBF:** ≥ 5 years

#### **Sockets for Waspote OEM:**

- SOCKET\_1

#### **Sockets for Plug & Sense!:**

- SOCKET\_B
- SOCKET\_C
- SOCKET\_F

**Average consumption:** 80 mA

**Note:** The CO<sub>2</sub> Sensor and the Methane (CH<sub>4</sub>) and Combustible Gas Sensor have high power requirements and cannot work together in the same Smart Cities PRO Sensor Board. The user must choose one or the other, but not both.

\* Accuracy values are only given for the **optimum case**. See the "Calibration" chapter in the Gases PRO Technical Guide for more detail.

Calibrated gas sensors are manufactured once the order has been placed to ensure maximum durability of the calibration feature. The manufacturing process and delivery may take from 4 to 6 weeks. The lifetime of calibrated gas sensors is 6 months working at maximum accuracy. We strongly encourage our customers to buy extra gas sensors to replace the original ones after that time to ensure maximum accuracy and performance.

You can find a complete example code for reading the CO<sub>2</sub> Sensor in the following link:

<http://www.libelium.com/development/waspmote/examples/scp-v30-02-ndir-gas-sensors>



Figure: Image of the Carbon Dioxide Sensor mounted on its AFE module

## 5.9. Molecular Oxygen (O<sub>2</sub>) Gas Sensor [Calibrated]

### 5.9.1. Specifications

**Gas:** O<sub>2</sub>

**Sensor:** 4-OL

#### Performance Characteristics

**Nominal Range:** 0 to 30 Vol.%

**Maximum Overload:** 90 Vol.%

**Long Term Output Drift:** < 2% signal/3 months

**Response Time (T90):** ≤ 30 seconds

**Sensitivity:** 1.66 ± 0.238 nA/ppm

**Accuracy:** as good as ± 0.1 % (ideal conditions)

#### Operation Conditions

**Temperature Range:** -20 °C to 50 °C

**Operating Humidity:** 5 to 90%RH non-condensing

**Pressure Range:** 90 to 110 kPa

**Storage Temperature:** 0 °C to 20 °C

**Expected Operating Life:** 2 years in air

#### **Sockets for Waspote OEM:**

- SOCKET\_1
- SOCKET\_3
- SOCKET\_5

#### **Sockets for Plug & Sense!:**

- SOCKET\_B
- SOCKET\_C
- SOCKET\_F

**Average consumption:** less than 1 mA

\* Accuracy values are only given for the **optimum case**. See the "Calibration" chapter in the Gases PRO Technical Guide for more detail.

The electrochemical sensors must be always powered on in order to get optimum measurements. This implies a power consumption, however it improves the performance of the sensor. This should also be applied when entering sleep modes so the sensor is not powered off selecting the proper sleep option.

Calibrated gas sensors are manufactured once the order has been placed to ensure maximum durability of the calibration feature. The manufacturing process and delivery may take from 4 to 6 weeks. The lifetime of calibrated gas sensors is 6 months working at maximum accuracy. We strongly encourage our customers to buy extra gas sensors to replace the original ones after that time to ensure maximum accuracy and performance.

You can find a complete example code for reading the O<sub>2</sub> Sensor in the following link:

[www.libelium.com/development/waspote/examples/scp-v30-01-electrochemical-gas-sensors](http://www.libelium.com/development/waspote/examples/scp-v30-01-electrochemical-gas-sensors)



Figure: Image of the Molecular Oxygen Sensor mounted on its AFE module

## 5.10. Ozone (O<sub>3</sub>) Gas Sensor [Calibrated]

### 5.10.1. Specifications

**Gas:** O<sub>3</sub>

**Sensor:** OX-A431

#### Performance Characteristics

**Nominal Range:** 0 to 18 ppm

**Maximum Overload:** 50 ppm

**Long Term sensitivity Drift:** -20 to -40% change/year

**Response Time (T90):** ≤ 45 seconds

**Sensitivity:** -200 to -550 nA/ppm

**Accuracy:** as good as ±0.2 ppm\* (ideal conditions)

High cross-sensitivity with NO<sub>2</sub> gas. Correction could be necessary in ambients with NO<sub>2</sub>.

#### Operation Conditions

**Temperature Range:** -30 °C to 40 °C

**Operating Humidity:** 15 to 85 %RH non-condensing

**Pressure Range:** 80 to 120 kPa

**Storage Temperature:** 3 °C to 20 °C

**Expected Operating Life:** > 24 months in air

#### **Sockets for Wasp mote OEM:**

- SOCKET\_1
- SOCKET\_3
- SOCKET\_5

#### **Sockets for Plug & Sense!:**

- SOCKET\_B
- SOCKET\_C
- SOCKET\_F

**Average consumption:** less than 1 mA

\* Accuracy values are only given for the **optimum case**. See the "Calibration" chapter in the Gases PRO Technical Guide for more detail.

The electrochemical sensors must be always powered on in order to get optimum measurements. This implies a power consumption, however it improves the performance of the sensor. This should also be applied when entering sleep modes so the sensor is not powered off selecting the proper sleep option.

Calibrated gas sensors are manufactured once the order has been placed to ensure maximum durability of the calibration feature. The manufacturing process and delivery may take from 4 to 6 weeks. The lifetime of calibrated gas sensors is 6 months working at maximum accuracy. We strongly encourage our customers to buy extra gas sensors to replace the original ones after that time to ensure maximum accuracy and performance.



Figure: Image of the Ozone Sensor mounted on its AFE module

## 5.10.2. Cross-sensitivity data

Gas	Formula	Concentration (ppm)	Output Signal (ppm CO equivalent)
Hydrogen Sulfide	H <sub>2</sub> S	5	< 100
Nitric Dioxide	NO <sub>2</sub>	5	70 to 120
Chlorine	Cl <sub>2</sub>	5	< 30
Nitric Oxide	NO	5	< 3
Sulfur Dioxide	SO <sub>2</sub>	5	< -6
Carbon Monoxide	CO	5	< 0.1
Hydrogen	H <sub>2</sub>	100	<0.1
Ethylene	C <sub>2</sub> H <sub>4</sub>	100	< 0.1
Ammonia	NH <sub>3</sub>	20	<0.1
Carbon Dioxide	CO <sub>2</sub>	50000	0.1
Halothane	Halothane	100	< 0.1

Figure: Cross-sensitivity data for the O<sub>3</sub> Sensor

This sensor has a **very high cross-sensitivity with NO<sub>2</sub> gas**. So, the output in ambients with NO<sub>2</sub> will be a mix of O<sub>3</sub> and NO<sub>2</sub>. A simple way to correct this effect is to subtract NO<sub>2</sub> concentration from O<sub>3</sub> concentration with an NO<sub>2</sub> gas sensor. The measure from the NO<sub>2</sub> sensor must be accurate in order to subtract the right value. **See the related section in the "Board configuration and programming" chapter to use the right function.**

You can find a complete example code for reading the O<sub>3</sub> Sensor in the following link:

[www.libelium.com/development/waspmote/examples/scp-v30-01-electrochemical-gas-sensors](http://www.libelium.com/development/waspmote/examples/scp-v30-01-electrochemical-gas-sensors)

## 5.11. Nitric Oxide (NO) Gas Sensor for low concentrations [Calibrated]

### 5.11.1. Specifications

**Gas:** NO

**Sensor:** NO-A4

#### Performance Characteristics

**Nominal Range:** 0 to 18 ppm

**Maximum Overload:** 50 ppm

**Long Term Sensitivity Drift:** < 20% change/year in lab air, monthly test

**Long Term zero Drift:** 0 to 50 ppb equivalent change/year in lab air

**Response Time (T90):** ≤ 25 seconds

**Sensitivity:** 350 to 550 nA/ppm

**Accuracy:** as good as ±0.2 ppm\* (ideal conditions)

#### Operation Conditions

**Temperature Range:** -30 °C to 50 °C

**Operating Humidity:** 15 to 85% RH non-condensing

**Pressure Range:** 80 to 120 kPa

**Storage Temperature:** 0 °C to 20 °C

**Expected Operating Life:** 2 years in air

#### **Sockets for Waspote OEM:**

- SOCKET\_1
- SOCKET\_3
- SOCKET\_5

#### **Sockets for Plug & Sense!:**

- SOCKET\_B
- SOCKET\_C
- SOCKET\_F

**Average consumption:** less than 1 mA

\* Accuracy values are only given for the **optimum case**. See the "Calibration" chapter in the Gases PRO Technical Guide for more detail.

The electrochemical sensors must be always powered on in order to get optimum measurements. This implies a power consumption, however it improves the performance of the sensor. This should also be applied when entering sleep modes so the sensor is not powered off selecting the proper sleep option.

Calibrated gas sensors are manufactured once the order has been placed to ensure maximum durability of the calibration feature. The manufacturing process and delivery may take from 4 to 6 weeks. The lifetime of calibrated gas sensors is 6 months working at maximum accuracy. We strongly encourage our customers to buy extra gas sensors to replace the original ones after that time to ensure maximum accuracy and performance.



*Figure: Image of the Nitric Oxide Sensor for low concentrations mounted on its AFE module*

### 5.11.2. Cross-sensitivity data

Gas	Formula	Concentration (ppm)	Output Signal (ppm NO equivalent)
Carbon Monoxide	CO	300	0
Sulfur Dioxide	SO <sub>2</sub>	5	0
Nitric Dioxide	NO <sub>2</sub>	5	1.5
Hydrogen Sulfide	H <sub>2</sub> S	15	-1.5

Figure: Cross-sensitivity data for the NO Sensor for low concentrations

You can find a complete example code for reading the NO Sensor for low concentrations in the following link: [www.libelium.com/development/waspmote/examples/scp-v30-01-electrochemical-gas-sensors](http://www.libelium.com/development/waspmote/examples/scp-v30-01-electrochemical-gas-sensors)

## 5.12. Nitric Dioxide (NO<sub>2</sub>) high accuracy Gas Sensor [Calibrated]

### 5.12.1. Specifications

**Gas:** NO<sub>2</sub>

**Sensor:** NO2-A43F

#### Performance Characteristics

**Nominal Range:** 0 to 20 ppm

**Maximum Overload:** 50 ppm

**Long Term Sensitivity Drift:** < -20 to -40% change/year in lab air, monthly test

**Long Term zero Drift:** < 20 ppb equivalent change/year in lab air

**Response Time (T90):** ≤ 60 seconds

**Sensitivity:** -175 to -450 nA/ppm

**Accuracy:** as good as ±0.1 ppm\* (ideal conditions)

**O3 filter capacity @ 2 ppm:** > 500 ppm·hrs

#### Operation Conditions

**Temperature Range:** -30 °C to 40 °C

**Operating Humidity:** 15 to 85% RH non-condensing

**Pressure Range:** 80 to 120 kPa

**Storage Temperature:** 0 °C to 20 °C

**Expected Operating Life:** 2 years in air

#### **Sockets for Waspote OEM:**

- SOCKET\_1
- SOCKET\_3
- SOCKET\_5

#### **Sockets for Plug & Sense!:**

- SOCKET\_B
- SOCKET\_C
- SOCKET\_F

**Average consumption:** less than 1 mA

\* Accuracy values are only given for the **optimum case**. See the "Calibration" chapter in the Gases PRO Technical Guide for more detail.

The electrochemical sensors must be always powered on in order to get optimum measurements. This implies a power consumption, however it improves the performance of the sensor. This should also be applied when entering sleep modes so the sensor is not powered off selecting the proper sleep option.

Calibrated gas sensors are manufactured once the order has been placed to ensure maximum durability of the calibration feature. The manufacturing process and delivery may take from 4 to 6 weeks. The lifetime of calibrated gas sensors is 6 months working at maximum accuracy. We strongly encourage our customers to buy extra gas sensors to replace the original ones after that time to ensure maximum accuracy and performance.



Figure: Image of the high accuracy Nitric Dioxide Sensor mounted on its AFE module



## 5.12.2. Cross-sensitivity data

Gas	Formula	Concentration (ppm)	Output Signal (ppm NO <sub>2</sub> equivalent)
Hydrogen Sulfide	H <sub>2</sub> S	5	< -80
Nitric Oxide	NO	5	< 5
Chlorine	Cl <sub>2</sub>	5	< 75
Sulfur Dioxide	SO <sub>2</sub>	5	< -5
Carbon Monoxide	CO	5	< -5
Ethylene	C <sub>2</sub> H <sub>4</sub>	100	< 1
Ammonia	NH <sub>3</sub>	20	< 0.2
Hydrogen	H <sub>2</sub>	100	< 0.1
Carbon Dioxide	CO <sub>2</sub>	5% vol	0.1
Halothane		100	nd

Figure: Cross-sensitivity data for the high accuracy NO<sub>2</sub> Sensor

You can find a complete example code for reading the high accuracy NO<sub>2</sub> Sensor in the following link:  
[www.libelium.com/development/waspmote/examples/scp-v30-01-electrochemical-gas-sensors](http://www.libelium.com/development/waspmote/examples/scp-v30-01-electrochemical-gas-sensors)

## 5.13. Sulfur Dioxide (SO<sub>2</sub>) high accuracy Gas Sensor [Calibrated]

### 5.13.1. Specifications

**Gas:** SO<sub>2</sub>

**Sensor:** SO2-A4

#### Performance Characteristics

**Nominal Range:** 0 to 20 ppm

**Maximum Overload:** 100 ppm

**Long Term Sensitivity Drift:** < ±15% change/year in lab air, monthly test

**Long Term zero Drift:** <±20 ppb equivalent change/year in lab air

**Response Time (T90):** ≤ 20 seconds

**Sensitivity:** 320 to 480 nA/ppm

**Accuracy:** as good as ±0.1 ppm\* (ideal conditions)

#### Operation Conditions

**Temperature Range:** -30 °C to 50 °C

**Operating Humidity:** 15 to 90% RH non-condensing

**Pressure Range:** 80 to 120 kPa

**Storage Temperature:** 0 °C to 20 °C

**Expected Operating Life:** 2 years in air

#### **Sockets for Waspote OEM:**

- SOCKET\_1
- SOCKET\_3
- SOCKET\_5

#### **Sockets for Plug & Sense!:**

- SOCKET\_B
- SOCKET\_C
- SOCKET\_F

**Average consumption:** less than 1 mA

\* Accuracy values are only given for the **optimum case**. See the "Calibration" chapter in the Gases PRO Technical Guide for more detail.

The electrochemical sensors must be always powered on in order to get optimum measurements. This implies a power consumption, however it improves the performance of the sensor. This should also be applied when entering sleep modes so the sensor is not powered off selecting the proper sleep option.

Calibrated gas sensors are manufactured once the order has been placed to ensure maximum durability of the calibration feature. The manufacturing process and delivery may take from 4 to 6 weeks. The lifetime of calibrated gas sensors is 6 months working at maximum accuracy. We strongly encourage our customers to buy extra gas sensors to replace the original ones after that time to ensure maximum accuracy and performance.



Figure: Image of the high accuracy Sulfur Dioxide Sensor mounted on its AFE module

### 5.13.2. Cross-sensitivity data

Gas	Formula	Concentration (ppm)	Output Signal (ppm SO <sub>2</sub> equivalent)
Hydrogen Sulfide	H <sub>2</sub> S	5	< 40
Nitric Oxide	NO	5	< -160
Chlorine	Cl <sub>2</sub>	5	< -70
Sulfur Dioxide	SO <sub>2</sub>	5	< -1.5
Carbon Monoxide	CO	5	< 2
Hydrogen	H <sub>2</sub>	100	< 1
Ethylene	C <sub>2</sub> H <sub>4</sub>	100	< 1
Ammonia	NH <sub>3</sub>	20	< 0.1
Carbon Dioxide	CO <sub>2</sub>	5% vol.	< 0.1

Figure: Cross-sensitivity data for the high accuracy SO<sub>2</sub> Sensor

You can find a complete example code for reading the high accuracy SO<sub>2</sub> Sensor in the following link:  
[www.libelium.com/development/waspmote/examples/scp-v30-01-electrochemical-gas-sensors](http://www.libelium.com/development/waspmote/examples/scp-v30-01-electrochemical-gas-sensors)

## 5.14. Ammonia (NH<sub>3</sub>) Gas Sensor for low concentrations [Calibrated]

### 5.14.1. Specifications

**Gas:** NH<sub>3</sub>

**Sensor:** 4-NH3-100

#### Performance Characteristics

**Nominal Range:** 0 to 100 ppm

**Long Term Output Drift:** < 2% signal/month

**Response Time (T90):** ≤ 90 seconds

**Sensitivity:** 135 ± 35 nA/ppm

**Accuracy:** as good as ±0.5 ppm\* (ideal conditions)

#### Operation Conditions

**Temperature Range:** -20 °C to 50 °C

**Operating Humidity:** 15 to 90%RH non-condensing

**Pressure Range:** 90 to 110 kPa

**Storage Temperature:** 0 °C to 20 °C

**Expected Operating Life:** ≥1 year in air

#### **Sockets for Waspote OEM:**

- SOCKET\_1
- SOCKET\_3
- SOCKET\_5

#### **Sockets for Plug & Sense!:**

- SOCKET\_B
- SOCKET\_C
- SOCKET\_F

**Average consumption:** less than 1 mA

\* Accuracy values are only given for the **optimum case**. See the "Calibration" chapter in the Gases PRO Technical Guide for more detail.

The electrochemical sensors must be always powered on in order to get optimum measurements. This implies a power consumption, however it improves the performance of the sensor. This should also be applied when entering sleep modes so the sensor is not powered off selecting the proper sleep option.

Calibrated gas sensors are manufactured once the order has been placed to ensure maximum durability of the calibration feature. The manufacturing process and delivery may take from 4 to 6 weeks. The lifetime of calibrated gas sensors is 6 months working at maximum accuracy. We strongly encourage our customers to buy extra gas sensors to replace the original ones after that time to ensure maximum accuracy and performance.



*Figure: Image of the Ammonia Sensor for low concentrations mounted on its AFE module*

## 5.14.2. Cross-sensitivity data

Gas	Formula	Concentration (ppm)	Output Signal (ppm NH <sub>3</sub> equivalent)
Carbon Monoxide	CO	300	0
Hydrogen Sulfide	H <sub>2</sub> S	5	1.5
Carbon dioxide	CO <sub>2</sub>	5	-3
Hydrogen	H <sub>2</sub>	15	30
Isobutylene		35	-1
Ethanol		100	0

Figure: Cross-sensitivity data for the NH<sub>3</sub> Sensor for low concentrations

You can find a complete example code for reading the NH<sub>3</sub> Sensor for low concentrations in the following link: [www.libelium.com/development/waspmote/examples/scp-v30-01-electrochemical-gas-sensors](http://www.libelium.com/development/waspmote/examples/scp-v30-01-electrochemical-gas-sensors)

## 5.15. Ammonia (NH<sub>3</sub>) Gas Sensor for high concentrations [Calibrated]

### 5.15.1. Specifications

**Gas:** NH<sub>3</sub>

**Sensor:** 4-NH3-100

#### Performance Characteristics

**Nominal Range:** 0 to 500 ppm

**Long Term Output Drift:** < 10% signal per 6 months

**Response Time (T90):** ≤ 90 seconds

**Sensitivity:** 135 ± 35 nA/ppm

**Accuracy:** as good as ±3 ppm\* (ideal conditions)

#### Operation Conditions

**Temperature Range:** -20 °C to 40 °C

**Operating Humidity:** 15 to 90% RH non-condensing

**Pressure Range:** 90 to 110 kPa

**Storage Temperature:** 0 °C to 20 °C

**Expected Operating Life:** ≥1 year in air

#### **Sockets for Waspote OEM:**

- SOCKET\_1
- SOCKET\_3
- SOCKET\_5

#### **Sockets for Plug & Sense!:**

- SOCKET\_B
- SOCKET\_C
- SOCKET\_F

**Average consumption:** less than 1 mA

\* Accuracy values are only given for the **optimum case**. See the "Calibration" chapter in the Gases PRO Technical Guide for more detail.

The electrochemical sensors must be always powered on in order to get optimum measurements. This implies a power consumption, however it improves the performance of the sensor. This should also be applied when entering sleep modes so the sensor is not powered off selecting the proper sleep option.

Calibrated gas sensors are manufactured once the order has been placed to ensure maximum durability of the calibration feature. The manufacturing process and delivery may take from 4 to 6 weeks. The lifetime of calibrated gas sensors is 6 months working at maximum accuracy. We strongly encourage our customers to buy extra gas sensors to replace the original ones after that time to ensure maximum accuracy and performance.



Figure: Image of the Ammonia Sensor for high concentrations mounted on its AFE module

## 5.15.2. Cross-sensitivity data

Gas	Concentration (ppm)	Output Signal (ppm NH <sub>3</sub> equivalent)
Carbon Monoxide	50	-1
Hydrogen Sulfide	25	85
Carbon dioxide	5000	-2.5
Hydrogen	1000	-1.5
Isobutylene	100	-1
Ethanol	1000	-1
Sulphur Dioxide	5	8
Nitric Oxide	35	0
Nitric Dioxide	5	-5
Chlorine	10	-5

Figure: Cross-sensitivity data for the NH<sub>3</sub> Sensor for high concentrations

You can find a complete example code for reading the NH<sub>3</sub> Sensor for high concentrations in the following link: <http://www.libelium.com/development/waspmote/examples/gp-v30-01-electrochemical-gas-sensors>

## 5.16. Methane (CH<sub>4</sub>) and Combustible Gas Sensor [Calibrated]

### 5.16.1. Specifications

**Main gas:** Methane CH<sub>4</sub>

**Sensor:** CH-A3

#### Performance Characteristics

**Nominal Range:** 0 to 100% LEL methane

**Long Term Output Drift:** < 2% signal/month

**Response Time (T90):** ≤ 30 seconds

**Accuracy:** as good as ±0.15% LEL\* (ideal conditions)

#### Operation Conditions

**Temperature Range:** -40 °C to 55 °C

**Expected Operating Life:** 2 years in air

#### Inhibition/Poisoning

Gas	Conditions	Effect
Chlorine	12hrs 20ppm Cl <sub>2</sub> , 50 % sensitivity loss, 2 day recovery	< 10% loss
Hydrogen Sulfide	12hrs 40ppm H <sub>2</sub> S, 50 % sensitivity loss, 2 day recovery	< 50% loss
HMDS	9 hrs @ 10ppm HMDS	50% activity loss

Figure: Inhibition and poisoning effects

#### Sockets for Waspote OEM:

- SOCKET\_1

#### Sockets for Plug & Sense!:

- SOCKET\_B
- SOCKET\_C
- SOCKET\_F

**Average consumption:** 68 mA

**Note:** The Methane (CH<sub>4</sub>) and Combustible Gas Sensor and the CO<sub>2</sub> Sensor have high power requirements and cannot work together in the same Smart Cities PRO Sensor Board. The user must choose one or the other, but not both.

\* Accuracy values are only given for the **optimum case**. See the "Calibration" chapter in the Gases PRO Technical Guide for more detail.



Figure: Image of the Methane (CH<sub>4</sub>) and Combustible Gas Sensor (pellistor) mounted on its AFE module



Calibrated gas sensors are manufactured once the order has been placed to ensure maximum durability of the calibration feature. The manufacturing process and delivery may take from 4 to 6 weeks. The lifetime of calibrated gas sensors is 6 months working at maximum accuracy. We strongly encourage our customers to buy extra gas sensors to replace the original ones after that time to ensure maximum accuracy and performance.

### 5.16.2. Sensitivity data

Hydrocarbon/Gas	% Sensitivity relative to Methane	% LEL Sensitivity to Methane
Hydrogen	130 to 140	160 to 175
Propane	150 to 190	350 to 450
Butane	150 to 180	420 to 500
n-Pentane	180 to 200	600 to 670
Nonane	150 to 170	800 to 950
Carbon Monoxide	42 to 44	17 to 18
Acetylene	150 to 170	300 to 340
Ethylene	150 to 170	270 to 320
Isobutylene	180 to 200	450 to 500

Figure: Sensitivity data for the CH<sub>4</sub> and Combustible Gases Sensor

You can find a complete example code for reading the Methane (CH<sub>4</sub>) and Combustible Gases Sensor in the following link:

<http://www.libelium.com/development/waspmote/examples/scp-v30-03-pellistor-gas-sensors>

## 5.17. Molecular Hydrogen (H<sub>2</sub>) Gas Sensor [Calibrated]

### 5.17.1. Specifications

**Gas:** H<sub>2</sub>

**Sensor:** 4-H2-1000

#### Performance Characteristics

**Nominal Range:** 0 to 1000 ppm

**Maximum Overload:** 2000 ppm

**Long Term Output Drift:** < 2% signal/month

**Response Time (T90):** ≤ 70 seconds

**Sensitivity:** 20 ± 10 nA/ppm

**Accuracy:** as good as ±10 ppm\* (ideal conditions)

#### Operation Conditions

**Temperature Range:** -20 °C to 50 °C

**Operating Humidity:** 15 to 90%RH non-condensing

**Pressure Range:** 90 to 110 kPa

**Storage Temperature:** 0 °C to 20 °C

**Expected Operating Life:** 2 years in air

#### **Sockets for Waspote OEM:**

- SOCKET\_1
- SOCKET\_3
- SOCKET\_5

#### **Sockets for Plug & Sense!:**

- SOCKET\_B
- SOCKET\_C
- SOCKET\_F

**Average consumption:** less than 1 mA

\* Accuracy values are only given for the **optimum case**. See the "Calibration" chapter in the Gases PRO Technical Guide for more detail.

The electrochemical sensors must be always powered on in order to get optimum measurements. This implies a power consumption, however it improves the performance of the sensor. This should also be applied when entering sleep modes so the sensor is not powered off selecting the proper sleep option.

Calibrated gas sensors are manufactured once the order has been placed to ensure maximum durability of the calibration feature. The manufacturing process and delivery may take from 4 to 6 weeks. The lifetime of calibrated gas sensors is 6 months working at maximum accuracy. We strongly encourage our customers to buy extra gas sensors to replace the original ones after that time to ensure maximum accuracy and performance.



Figure: Image of the Molecular Hydrogen Sensor mounted on its AFE module

### 5.17.2. Cross-sensitivity data

Gas	Formula	Concentration (ppm)	Output Signal (ppm H <sub>2</sub> equivalent)
Hydrogen Sulfide	H <sub>2</sub> S	24	0
Sulfur Dioxide	SO <sub>2</sub>	5	0
Nitric Oxide	NO	35	10
Nitric Dioxide	NO <sub>2</sub>	5	0
Carbon Monoxide	CO	50	200
Ethylene	C <sub>2</sub> H <sub>4</sub>	100	80
Chlorine	Cl <sub>2</sub>	10	0

Figure: Cross-sensitivity data for the H<sub>2</sub> Sensor

You can find a complete example code for reading the H<sub>2</sub> Sensor in the following link:

[www.libelium.com/development/waspmote/examples/scp-v30-01-electrochemical-gas-sensors](http://www.libelium.com/development/waspmote/examples/scp-v30-01-electrochemical-gas-sensors)

## 5.18. Hydrogen Sulfide (H<sub>2</sub>S) Gas Sensor [Calibrated]

### 5.18.1. Specifications

**Gas:** H<sub>2</sub>S

**Sensor:** 4-H2S-100

#### Performance Characteristics

**Nominal Range:** 0 to 100 ppm

**Maximum Overload:** 50 ppm

**Long Term Output Drift:** < 2% signal/month

**Response Time (T90):** ≤ 20 seconds

**Sensitivity:** 800 ± 200 nA/ppm

**Accuracy:** as good as ±0.1 ppm\* (ideal conditions)

#### Operation Conditions

**Temperature Range:** -20 °C to 50 °C

**Operating Humidity:** 15 to 90%RH non-condensing

**Pressure Range:** 90 to 110 kPa

**Storage Temperature:** 0 °C to 20 °C

**Expected Operating Life:** 2 years in air

#### **Sockets for Waspote OEM:**

- SOCKET\_1
- SOCKET\_3
- SOCKET\_5

#### **Sockets for Plug & Sense!:**

- SOCKET\_B
- SOCKET\_C
- SOCKET\_F

**Average consumption:** less than 1 mA

\* Accuracy values are only given for the **optimum case**. See the "Calibration" chapter in the Gases PRO Technical Guide for more detail.

The electrochemical sensors must be always powered on in order to get optimum measurements. This implies a power consumption, however it improves the performance of the sensor. This should also be applied when entering sleep modes so the sensor is not powered off selecting the proper sleep option.

Calibrated gas sensors are manufactured once the order has been placed to ensure maximum durability of the calibration feature. The manufacturing process and delivery may take from 4 to 6 weeks. The lifetime of calibrated gas sensors is 6 months working at maximum accuracy. We strongly encourage our customers to buy extra gas sensors to replace the original ones after that time to ensure maximum accuracy and performance.



Figure: Image of the Hydrogen Sulfide Sensor mounted on its AFE module

## 5.18.2. Cross-sensitivity data

Gas	Formula	Concentration (ppm)	Output Signal (ppm H <sub>2</sub> S equivalent)
Carbon Monoxide	CO	50	≤6
Sulfur Dioxide	SO <sub>2</sub>	5	1
Nitric Oxide	NO	35	1
Nitric Dioxide	NO <sub>2</sub>	5	-1
Hydrogen	H <sub>2</sub>	10000	25
Ethylene	C <sub>2</sub> H <sub>4</sub>	100	0
Ethanol	C <sub>2</sub> H <sub>6</sub> O	5000	±1.5

Figure: Cross-sensitivity data for the H<sub>2</sub>S Sensor

You can find a complete example code for reading the H<sub>2</sub>S Sensor in the following link:

[www.libelium.com/development/waspmote/examples/scp-v30-01-electrochemical-gas-sensors](http://www.libelium.com/development/waspmote/examples/scp-v30-01-electrochemical-gas-sensors)

## 5.19. Hydrogen Chloride (HCl) Gas Sensor [Calibrated]

### 5.19.1. Specifications

**Gas:** HCl

**Sensor:** 4-HCl-50

#### Performance Characteristics

**Nominal Range:** 0 to 50 ppm

**Maximum Overload:** 100 ppm

**Long Term Output Drift:** < 2% signal/month

**Response Time (T90):** ≤ 70 seconds

**Sensitivity:** 300 ± 100 nA/ppm

**Accuracy:** as good as ±1 ppm\* (ideal conditions)

#### Operation Conditions

**Temperature Range:** -20 °C to 50 °C

**Operating Humidity:** 15 to 90%RH non-condensing

**Pressure Range:** 90 to 110 kPa

**Storage Temperature:** 0 °C to 20 °C

**Expected Operating Life:** 2 years in air

#### **Sockets for Waspote OEM:**

- SOCKET\_1
- SOCKET\_3
- SOCKET\_5

#### **Sockets for Plug & Sense!:**

- SOCKET\_B
- SOCKET\_C
- SOCKET\_F

**Average consumption:** less than 1 mA

\* Accuracy values are only given for the **optimum case**. See the "Calibration" chapter in the Gases PRO Technical Guide for more detail.

The electrochemical sensors must be always powered on in order to get optimum measurements. This implies a power consumption, however it improves the performance of the sensor. This should also be applied when entering sleep modes so the sensor is not powered off selecting the proper sleep option.

Calibrated gas sensors are manufactured once the order has been placed to ensure maximum durability of the calibration feature. The manufacturing process and delivery may take from 4 to 6 weeks. The lifetime of calibrated gas sensors is 6 months working at maximum accuracy. We strongly encourage our customers to buy extra gas sensors to replace the original ones after that time to ensure maximum accuracy and performance.



Figure: Image of the Hydrogen Chloride Sensor mounted on its AFE module

## 5.19.2. Cross-sensitivity data

Gas	Formula	Concentration (ppm)	Output Signal (ppm HCl equivalent)
Hydrogen	H <sub>2</sub>	2000	0
Carbon Monoxide	CO	100	0
Nitric Oxide	NO	20	50
Nitric Dioxide	NO <sub>2</sub>	10	1
Hydrogen Sulfide	H <sub>2</sub> S	25	130
Sulfur Dioxide	SO <sub>2</sub>	20	35
Nitrogen	N	1000000	0

Figure: Cross-sensitivity data for the HCl Sensor

You can find a complete example code for reading the HCl Sensor in the following link:

[www.libelium.com/development/waspmote/examples/scp-v30-01-electrochemical-gas-sensors](http://www.libelium.com/development/waspmote/examples/scp-v30-01-electrochemical-gas-sensors)

## 5.20. Hydrogen Cyanide (HCN) Gas Sensor [Calibrated]

### 5.20.1. Specifications

**Gas:** HCN

**Sensor:** 4-HCN-50

#### Performance Characteristics

**Nominal Range:** 0 to 50 ppm

**Maximum Overload:** 100 ppm

**Long Term Output Drift:** < 2% signal/month

**Response Time (T90):** ≤ 120 seconds

**Sensitivity:** 100 ± 20 nA/ppm

**Accuracy:** as good as ±0.2 ppm\* (ideal conditions)

#### Operation Conditions

**Temperature Range:** -20 °C to 50 °C

**Operating Humidity:** 15 to 90%RH non-condensing

**Pressure Range:** 90 to 110 kPa

**Storage Temperature:** 0 °C to 20 °C

**Expected Operating Life:** 2 years in air

#### **Sockets for Waspote OEM:**

- SOCKET\_1
- SOCKET\_3
- SOCKET\_5

#### **Sockets for Plug & Sense!:**

- SOCKET\_1
- SOCKET\_3
- SOCKET\_5

**Average consumption:** less than 1 mA

\* Accuracy values are only given for the **optimum case**. See the "Calibration" chapter in the Gases PRO Technical Guide for more detail.

The electrochemical sensors must be always powered on in order to get optimum measurements. This implies a power consumption, however it improves the performance of the sensor. This should also be applied when entering sleep modes so the sensor is not powered off selecting the proper sleep option.

Calibrated gas sensors are manufactured once the order has been placed to ensure maximum durability of the calibration feature. The manufacturing process and delivery may take from 4 to 6 weeks. The lifetime of calibrated gas sensors is 6 months working at maximum accuracy. We strongly encourage our customers to buy extra gas sensors to replace the original ones after that time to ensure maximum accuracy and performance.



Figure: Image of the Hydrogen Cyanide Sensor mounted on its AFE module



## 5.20.2. Cross-sensitivity data

Gas	Formula	Concentration (ppm)	Output Signal (ppm HCN equivalent)
Carbon Monoxide	CO	300	0
Sulfur Dioxide	SO <sub>2</sub>	5	1.5
Nitric Dioxide	NO <sub>2</sub>	5	-3
Hydrogen Sulfide	H <sub>2</sub> S	15	30
Nitric Oxide	NO	35	-1
Ethylene	C <sub>2</sub> H <sub>4</sub>	100	0

Figure: Cross-sensitivity data for the HCN Sensor

You can find a complete example code for reading the HCN Sensor in the following link:

[www.libelium.com/development/waspmote/examples/scp-v30-01-electrochemical-gas-sensors](http://www.libelium.com/development/waspmote/examples/scp-v30-01-electrochemical-gas-sensors)

## 5.21. Phosphine (PH<sub>3</sub>) Gas Sensor [Calibrated]

### 5.21.1. Specifications

**Gas:** PH<sub>3</sub>

**Sensor:** 4-PH3-20

#### Performance Characteristics

**Nominal Range:** 0 to 20 ppm

**Maximum Overload:** 100 ppm

**Long Term Output Drift:** < 2% signal/month

**Response Time (T90):** ≤ 60 seconds

**Sensitivity:** 1400 ± 600 nA/ppm

**Accuracy:** as good as ±0.1 ppm\* (ideal conditions)

#### Operation Conditions

**Temperature Range:** -20 °C to 50 °C

**Operating Humidity:** 15 to 90%RH non-condensing

**Pressure Range:** 90 to 110 kPa

**Storage Temperature:** 0 °C to 20 °C

**Expected Operating Life:** 2 years in air

#### **Sockets for Waspote OEM:**

- SOCKET\_1
- SOCKET\_3
- SOCKET\_5

#### **Sockets for Plug & Sense!:**

- SOCKET\_B
- SOCKET\_C
- SOCKET\_F

**Average consumption:** less than 1 mA

\* Accuracy values are only given for the **optimum case**. See the "Calibration" chapter in the Gases PRO Technical Guide for more detail.

The electrochemical sensors must be always powered on in order to get optimum measurements. This implies a power consumption, however it improves the performance of the sensor. This should also be applied when entering sleep modes so the sensor is not powered off selecting the proper sleep option.

Calibrated gas sensors are manufactured once the order has been placed to ensure maximum durability of the calibration feature. The manufacturing process and delivery may take from 4 to 6 weeks. The lifetime of calibrated gas sensors is 6 months working at maximum accuracy. We strongly encourage our customers to buy extra gas sensors to replace the original ones after that time to ensure maximum accuracy and performance.



Figure: Image of the Phosphine Gas Sensor mounted on its AFE module

## 5.21.2. Cross-sensitivity data

Gas	Formula	Concentration (ppm)	Output Signal (ppm PH <sub>3</sub> equivalent)
Carbon Monoxide	CO	1000	0
Hydrogen Sulfide	H <sub>2</sub> S	15	12
Sulfur Dioxide	SO <sub>2</sub>	5	0.9
Hydrogen	H <sub>2</sub>	1000	0
Ethylene	C <sub>2</sub> H <sub>4</sub>	100	0
Ammonia	NH <sub>3</sub>	50	0

Figure: Cross-sensitivity data for the PH<sub>3</sub> Sensor

You can find a complete example code for reading the PH<sub>3</sub> Sensor in the following link:

[www.libelium.com/development/waspmote/examples/scp-v30-01-electrochemical-gas-sensors](http://www.libelium.com/development/waspmote/examples/scp-v30-01-electrochemical-gas-sensors)

## 5.22. Ethylene Oxide (ETO) Gas Sensor [Calibrated]

### 5.22.1. Specifications

**Gas:** ETO

**Sensor:** 4-ETO-100

#### Performance Characteristics

**Nominal Range:** 0 to 100 ppm

**Long Term Sensitivity Drift:** < 2% signal/month

**Response Time (T90):** ≤ 120 seconds

**Sensitivity:** 250 ± 125 nA/ppm

**Accuracy:** as good as ±1 ppm\* (ideal conditions)

#### Operation Conditions

**Temperature Range:** -20 °C to 50 °C

**Operating Humidity:** 15 to 90%RH non-condensing

**Pressure Range:** 90 to 110 kPa

**Storage Temperature:** 0 °C to 20 °C

**Expected Operating Life:** 5 years in air

#### **Sockets for Wasp mote OEM:**

- SOCKET\_1
- SOCKET\_3
- SOCKET\_5

#### **Sockets for Plug & Sense!:**

- SOCKET\_B
- SOCKET\_C
- SOCKET\_F

**Average consumption:** less than 1 mA

\* Accuracy values are only given for the **optimum case**. See the "Calibration" chapter in the Gases PRO Technical Guide for more detail.

The electrochemical sensors must be always powered on in order to get optimum measurements. This implies a power consumption, however it improves the performance of the sensor. This should also be applied when entering sleep modes so the sensor is not powered off selecting the proper sleep option.

Calibrated gas sensors are manufactured once the order has been placed to ensure maximum durability of the calibration feature. The manufacturing process and delivery may take from 4 to 6 weeks. The lifetime of calibrated gas sensors is 6 months working at maximum accuracy. We strongly encourage our customers to buy extra gas sensors to replace the original ones after that time to ensure maximum accuracy and performance.



Figure: Image of the Ethylene Oxide Sensor mounted on its AFE module

## 5.22.2. Cross-sensitivity data

Gas	Formula	Sensitivity of ETO/Sensitivity of test gas
Ethylene Oxide	ETO	1.0
Carbon Monoxide	CO	2.5
Ethanol	C <sub>2</sub> H <sub>6</sub> O	2.0
Methanol	CH <sub>4</sub> O	0.5
Isopropanol	C <sub>3</sub> H <sub>8</sub> O	5.0
i-Butylene		2.5
Butadiene	C <sub>4</sub> H <sub>6</sub>	0.9
Ethylene	C <sub>2</sub> H <sub>4</sub>	0.8
Propene	C <sub>3</sub> H <sub>6</sub>	1.7
Vinyl Chloride	C <sub>2</sub> H <sub>3</sub> Cl	1.3
Vinyl Acetate	C <sub>4</sub> H <sub>6</sub> O <sub>2</sub>	2.0
Formic Acid	CH <sub>2</sub> O <sub>2</sub>	3.3
Ethyl ether	(C <sub>2</sub> H <sub>5</sub> ) <sub>2</sub> O	2.5
Formaldehyde	CH <sub>2</sub> O	1.0

Figure: Cross-sensitivity data for the ETO Sensor

You can find a complete example code for reading the ETO Sensor in the following link:

[www.libelium.com/development/waspmote/examples/scp-v30-01-electrochemical-gas-sensors](http://www.libelium.com/development/waspmote/examples/scp-v30-01-electrochemical-gas-sensors)

## 5.23. Chlorine (Cl<sub>2</sub>) Gas Sensor [Calibrated]

### 5.23.1. Specifications

**Gas:** Cl<sub>2</sub>

**Sensor:** 4-Cl2-50

#### Performance Characteristics

**Nominal Range:** 0 to 50 ppm

**Maximum Overload:** 100 ppm

**Long Term Output Drift:** < 2% signal/month

**Response Time (T90):** ≤ 30 seconds

**Sensitivity:** 450 ± 200 nA/ppm

**Accuracy:** as good as ±0.1 ppm\* (ideal conditions)

#### Operation Conditions

**Temperature Range:** -20 °C to 50 °C

**Operating Humidity:** 15 to 90%RH non-condensing

**Pressure Range:** 90 to 110 kPa

**Storage Temperature:** 0 °C to 20 °C

**Expected Operating Life:** 2 years in air

#### **Sockets for Waspote OEM:**

- SOCKET\_1
- SOCKET\_3
- SOCKET\_5

#### **Sockets for Plug & Sense!:**

- SOCKET\_B
- SOCKET\_C
- SOCKET\_F

**Average consumption:** less than 1 mA

\* Accuracy values are only given for the **optimum case**. See the "Calibration" chapter in the Gases PRO Technical Guide for more detail.

The electrochemical sensors must be always powered on in order to get optimum measurements. This implies a power consumption, however it improves the performance of the sensor. This should also be applied when entering sleep modes so the sensor is not powered off selecting the proper sleep option.

Calibrated gas sensors are manufactured once the order has been placed to ensure maximum durability of the calibration feature. The manufacturing process and delivery may take from 4 to 6 weeks. The lifetime of calibrated gas sensors is 6 months working at maximum accuracy. We strongly encourage our customers to buy extra gas sensors to replace the original ones after that time to ensure maximum accuracy and performance.



Figure: Image of the Chlorine Sensor mounted on its AFE module

### 5.23.2. Cross-sensitivity data

Gas	Formula	Concentration (ppm)	Output Signal (ppm Cl <sub>2</sub> equivalent)
Hydrogen Sulfide	H <sub>2</sub> S	20	-4
Carbon Monoxide	CO	100	0
Sulfur Dioxide	SO <sub>2</sub>	20	0
Nitric Oxide	NO	35	0
Nitric Dioxide	NO <sub>2</sub>	10	12
Hydrogen	H <sub>2</sub>	3000	0
Ammonia	NH <sub>3</sub>	100	0
Carbon Dioxide	CO <sub>2</sub>	10000	0
Chlorine Dioxide	ClO <sub>2</sub>	1	3.5

Figure: Cross-sensitivity data for the Cl<sub>2</sub> Sensor

You can find a complete example code for reading the Cl<sub>2</sub> Sensor in the following link:

[www.libelium.com/development/waspmote/examples/scp-v30-01-electrochemical-gas-sensors](http://www.libelium.com/development/waspmote/examples/scp-v30-01-electrochemical-gas-sensors)

## 5.24. Important notes for Calibrated Sensors



**1°** - Calibrated gas sensors are manufactured once the order has been placed to ensure maximum durability of the calibration feature. Manufacturing process and delivery may take from 4 to 6 weeks.

**2°** - Lifetime of calibrated gas sensors is 6 months working at its maximum accuracy as every sensor loses a small percentage of its original calibration monthly in a range that may go from 0.5% to 2%. We strongly encourage our customers to buy extra gas sensor probes to replace the originals after that time to ensure maximum accuracy and performance. Any sensor should be understood as a disposable item; that means that after some months it should be replaced by a new unit.

**3°** - Electrochemical calibrated gas sensors are a good alternative to the professional metering gas stations however they have some limitations. The most important parameters of each sensor are the nominal range and the accuracy. If you need to reach an accuracy of  $\pm 0.1$  ppm remember not to choose a sensor with an accuracy of  $\pm 1$  ppm. Take a look in the chapter dedicated to each sensor in the Gases PRO Guide (Development section on the Libelium website). We show a summary table at the end of the current document for quick reference.

**4°** - Libelium indicates an accuracy for each sensor just as an **ideal reference** (for example, " $\pm 0.1$  ppm"). This theoretical figure has been calculated as the best error the user could expect, the optimum case. In real conditions, the measurement error **may be bigger** (for example, " $\pm 0.3$  ppm"). The older the sensor is, the more deteriorated it is, so the accuracy gets worse. Also, the more extreme the concentration to meter is, the worse the accuracy is. And also, the more extreme the environmental conditions are, the quicker the sensor decreases its accuracy.

**5°** - In order to increase the accuracy and reduce the response time we strongly recommend to keep the gas sensor board ON as electrochemical sensors have a very low consumption (less than 1 mA). So these sensors should be left powered ON while Waspote enters into deepsleep mode. Latest code examples implement in the new API of Waspote v15 follow this strategy. If you are using the old version of the API and boards (v12) write in our Forum and we will help you to modify your code.

**6°** - These sensors need a stabilization time to work properly, in some cases hours. We recommend wait 24hours of functioning (always with the gas sensor board ON) to ensure that the values of the sensors are stable.

**7°** - AFE boards for electrochemical gas sensors have different gain options. The system integrator must choose the adequate gain according to the concentration range to measure. For low concentrations, higher gains are recommended. To know how choosing the right gain, see the chapter "How to choose the right gain resistor" from the Gases PRO Guide.

**8°** - A digital smoothing filter based on previous values is interesting to reduce noise. It will increase the accuracy of the gases PRO sensors. The filter adequate for its application (note that every sample given by the library has already been filtered inside Waspote) means from 4 to 8 values.

A simple moving average can be used to increase the accuracy and reduce the noise.

$$\text{Filtered value} = \frac{\text{sample}_t + \text{sample}_{t-1} + \text{sample}_{t-2} + \dots + \text{sample}_{t-(n-1)}}{n}$$

Where:

- Filtered value are the concentration value with the mean filter applied
- $\text{sample}_t$  are the measurements taken by the gas sensors being  $\text{sample}_t$  the last measurement,  $\text{sample}_{t-1}$  the penultimate measurement, etc
- $n$  are the number of samples to calculate the moving mean



Other filters can be applied according to the project requirements.

9° - Take into account that developing a robust application for gases detection or measurement may take an important effort of testing and knowing the insights of the sensor probes and code that reads them.

### Calibrated Gas Table

Parameter	Range	Calibration	Max consumption
Temperature	-40 to +85 °C	Calibrated ±1 °C (±0.5 °C at 25 °C)	2 µA @ 3V3
Humidity	0 to 100% HR	Calibrated ±3% RH (at 25 °C, range 20 ~ 80% RH)	2.8 µA @ 3V3
Pressure	30 to 110 kPa	Calibrated ±0.1 kPa (range 0 ~ 65 °C)	4.2 µA @ 3V3
Carbon Monoxide for high concentrations CO	0 to 500 ppm	Calibrated ±1 ppm	351 µA @ 3V3
Carbon Monoxide for low concentrations CO	0 to 25 ppm	Calibrated ±0.1 - 0.7 ppm	312 µA @ 3V3
Carbon Dioxide CO <sub>2</sub>	0 to 5000 ppm	Calibrated ±50 ppm (range 0~2500 ppm) ±200 ppm (range 2500~5000 ppm)	85 mA @ 3V3
Molecular Oxygen O <sub>2</sub>	0 to 30%	Calibrated ±0.1%	402 µA @ 3V3
Ozone O <sub>3</sub>	0 to 18 ppm	Calibrated ±0.2 - 0.7 ppm	< 1 mA @ 3V3
Nitric Oxide for low concentrations NO	0 to 18 ppm	Calibrated ±0.2 - 0.5 ppm	392 µA @ 3V3
Nitric Dioxide NO <sub>2</sub> high accuracy	0 to 20 ppm	Calibrated ±0.1- 0.2 ppm	330 µA @ 3V3
Sulfur Dioxide SO <sub>2</sub> high accuracy	0 to 20 ppm	Calibrated ±0.1 - 0.4 ppm	333 µA @ 3V3
Ammonia for low concentrations NH <sub>3</sub>	0 to 100 ppm	Calibrated ±0.5 ppm	338 µA @ 3V3
Ammonia for high concentrations NH <sub>3</sub>	0 to 500 ppm	Calibrated ±3 ppm	338 µA @ 3V3
Methane and other combustible gases CH <sub>4</sub>	0 to 100% / LEL	Calibrated ±0.15% LEL	68 mA @ 3V3
Molecular Hydrogen H <sub>2</sub>	0 to 1000 ppm	Calibrated ±10 ppm	520 µA @ 3V3

Hydrogen Sulfide H <sub>2</sub> S	0 to 100 ppm	Calibrated ±0.1 ppm	352 µA @ 3V3
Hydrogen Chloride HCl	0 to 50 ppm	Calibrated ±1 ppm	341 µA @ 3V3
Hydrogen Cyanide HCN	0 to 50 ppm	Calibrated ±0.2 ppm	327 µA @ 3V3
Phosphine PH <sub>3</sub>	0 to 20 ppm	Calibrated ±0.1 ppm	361 µA @ 3V3
Ethylene Oxide ETO	0 to 100 ppm	Calibrated ±1 ppm	360 µA @ 3V3
Chlorine Cl <sub>2</sub>	0 to 50 ppm	Calibrated ±0.1 ppm	353 µA @ 3V3
Particle Matter – Dust	0.5 to 16 µm (16 steps) (includes PM1, PM2.5 and PM10)	Calibrated	200+ mA @ 5 V

**Comparative between Libelium HW with Alphasense sensors and Alphasense HW with Alphasense sensors**

**1. Ozone**

**Sensor 1 - Alphasense (blue)**

Real Input (ppm)	Medium Measured Value (ppm)	Error (ppm)
0 ppm	-1,641	1,641
1 ppm	-0,815	1,815
6 ppm	5,77	0,221

**Sensor 2 - Libelium (red)**

Real Input (ppm)	Medium Measured Value	Error
0 ppm	-0,861	0,861
1 ppm	0,210	0,789
6 ppm	7,039	1,039

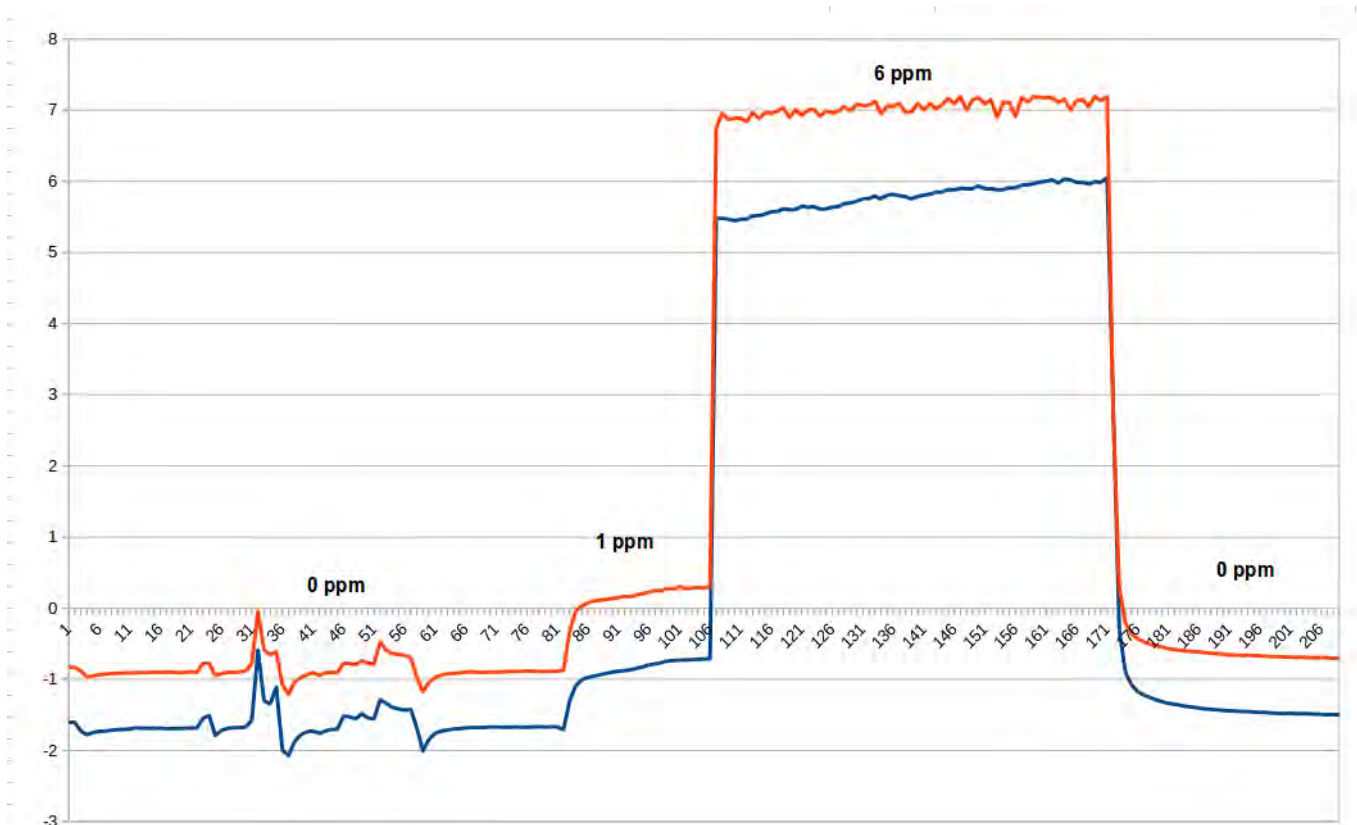

## 2. NO

### Sensor 1 - Alphasense (blue)

Real Input (ppm)	Medium Measured Value (ppm)	Error (ppm)
7 ppm	6,182	0,818
2 ppm	1,840	0,160
0 ppm	-0,4098	0,4098

### Sensor 2 - Libelium (red)

Real Input (ppm)	Medium Measured Value (ppm)	Error (ppm)
7 ppm	6,478	0,521
2 ppm	1,919	0,08
0 ppm	-0,260	0,260

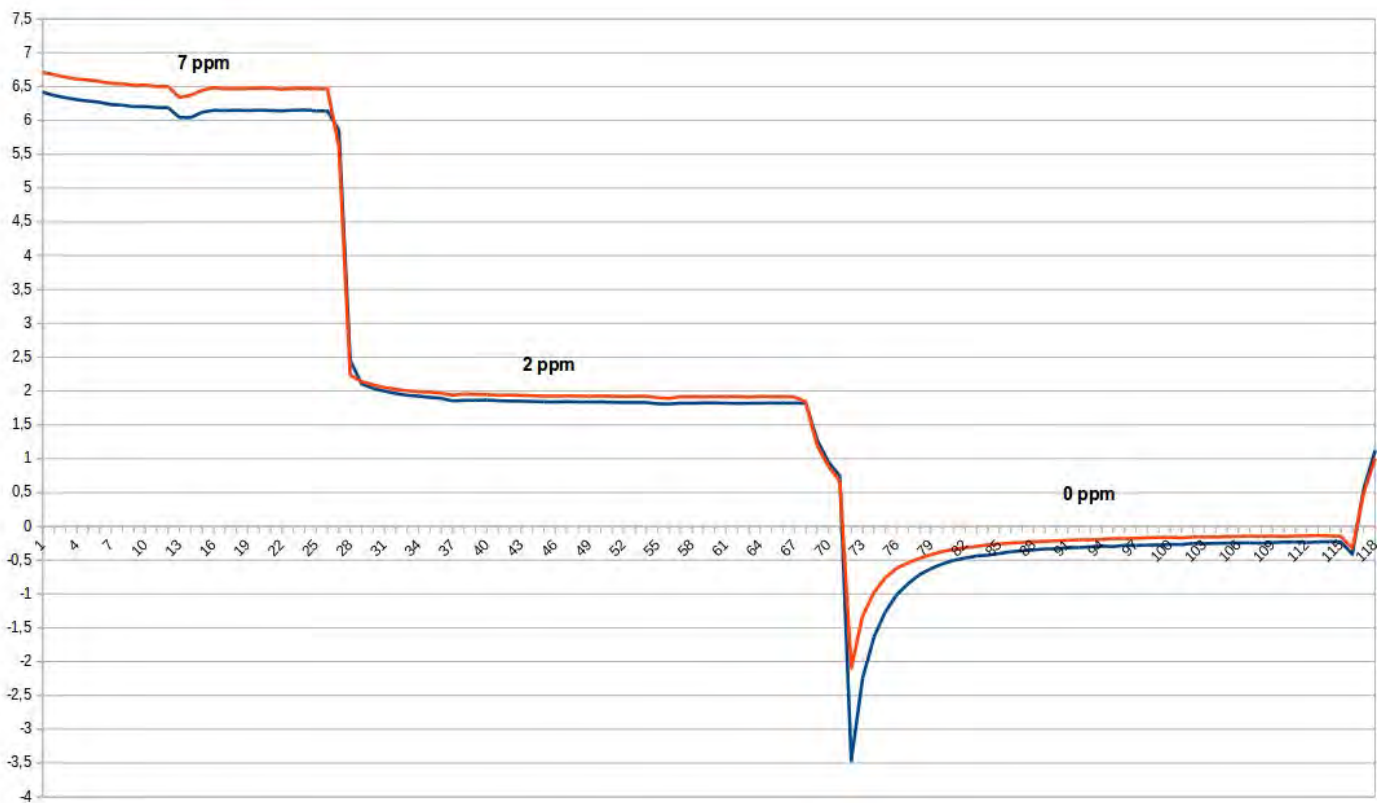

### 3. CO

#### Sensor 1 - Alphasense (blue)

Real Input (ppm)	Medium Measured Value (ppm)	Error (ppm)
10 ppm	10,76	-0,766
0 ppm	0,826	-0,826
1 ppm	1,718	-0,718

#### Sensor 2 - Libelium (red)

Real Input (ppm)	Medium Measured Value (ppm)	Error (ppm)
10 ppm	10,66	-0,066
0 ppm	0,790	-0,790
1 ppm	1,636	-0,636

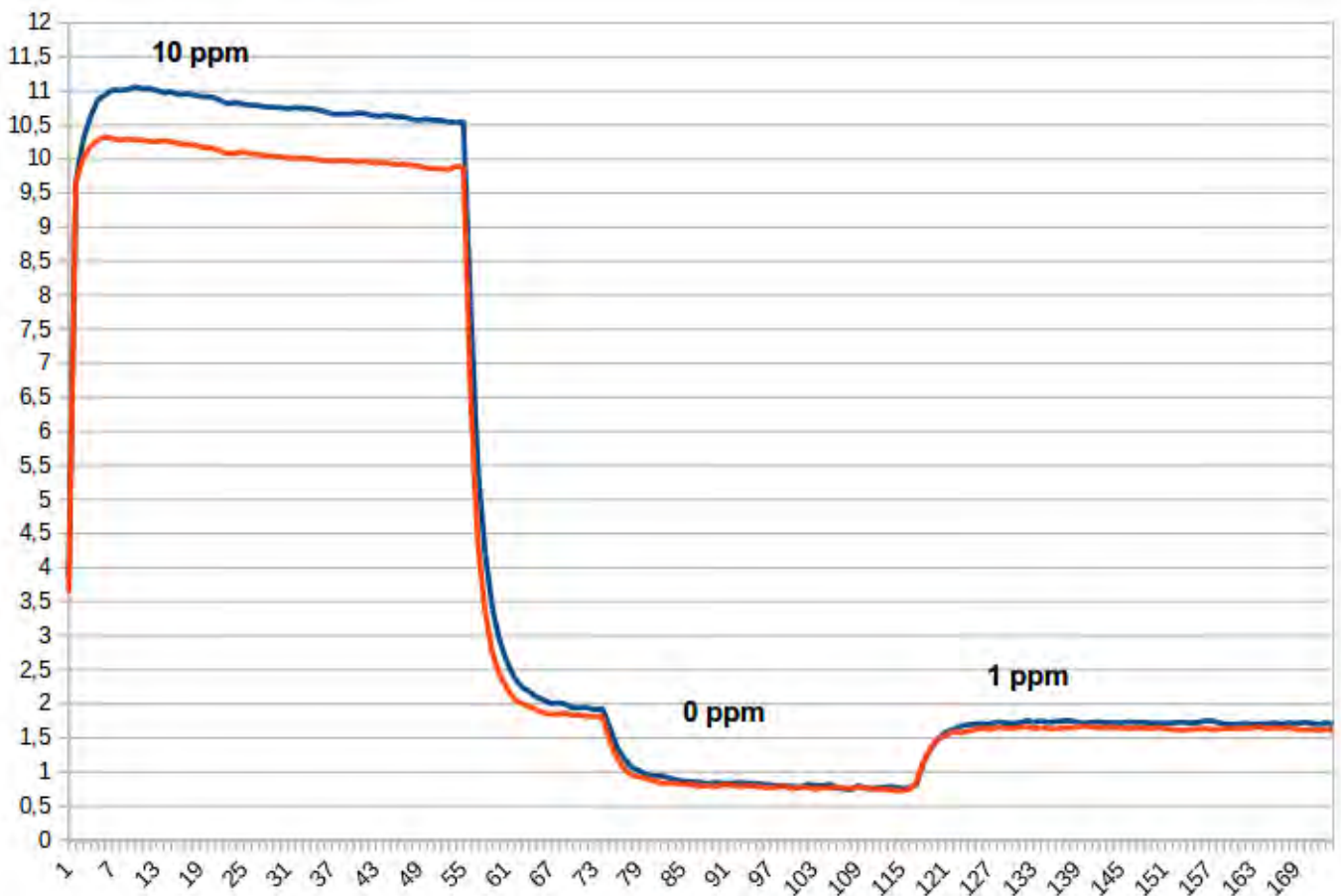

## 4. SO<sub>2</sub>

### Sensor 1 - Alphasense (blue)

Real Input (ppm)	Medium Measured Value (ppm)	Error (ppm)
4 ppm	4,183	-0,183
0 ppm	0,373	-0,373
8 ppm	7,85	0,146

### Sensor 2 - Libelium (red)

Real Input (ppm)	Medium Measured Value (ppm)	Error (ppm)
4 ppm	4,451	-0,451
0 ppm	0,5779	-0,5779
8 ppm	7,641	0,358

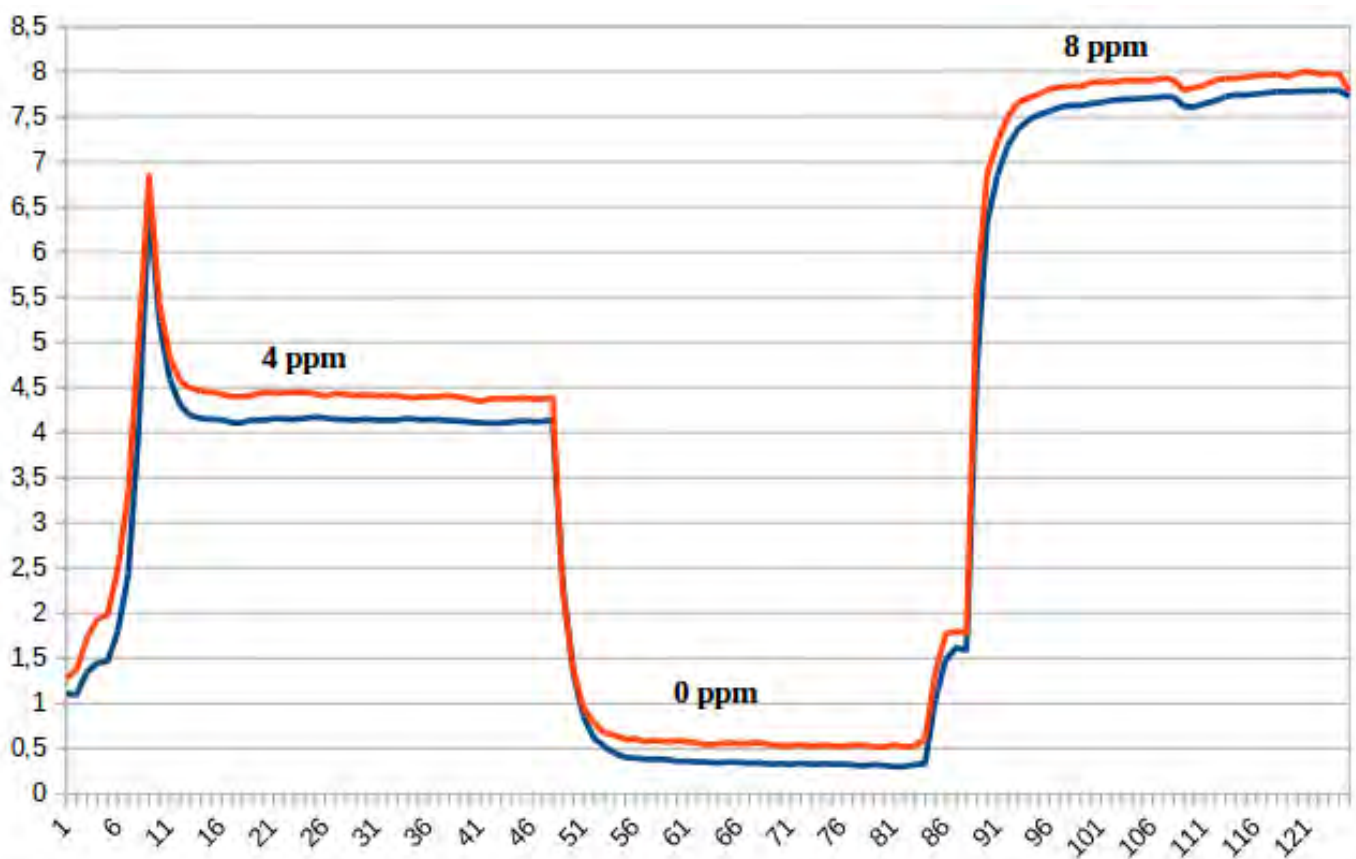

## 5. NO<sub>2</sub>

### Sensor 1 - Libelium (red)

Real Input (ppm)	Medium Measured Value (ppm)	Error (ppm)
1	0,721	0,278
3	2,776	0,223
0	-0,163	0,163

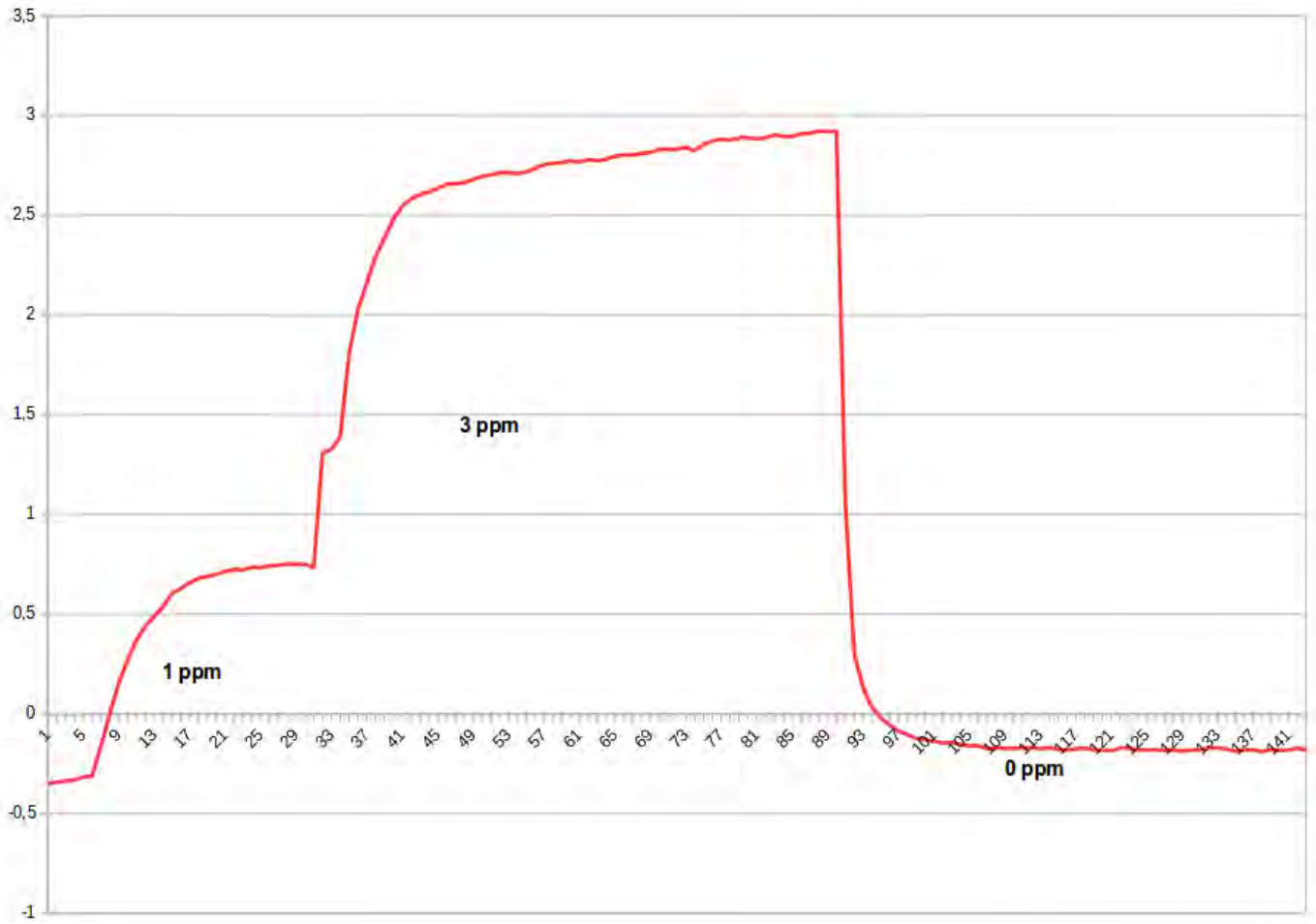

## 6. Board configuration and programming

### 6.1. Hardware configuration

The Smart Cities PRO board does not require of any handling of the hardware by the user except for placing the sensors in their corresponding position. In the section dedicated to each connector we can see an image of the connections between the socket and its corresponding sensor.

### 6.2. API

#### 6.2.1. Before starting to program

When using the Smart Cities PRO Sensor Board on Waspote, remember it is mandatory to include the WaspSensorCities\_Pro library by introducing the next line at the beginning of the code:

```
#include <WaspSensorCities_PRO.h>
```

The library manages the power supply and communication lines between Waspote and the sockets. To manage each sensor the user must use the specific library and guide for each sensor.

#### 6.2.2. Gases sensors

In order to manage a gas sensor, the user must define a "Gas" library object. The user must also indicate the socket used in the class constructor. The available sockets for gases sensors are: sockets 1, 3 and 5 for the OEM line; and sockets B, C and F for the Plug and Sense! line. For instance:

```
Gas gas_sensor(SOCKET_B);
```

The electrochemical sensors must be switched on at the beginning of the code in order to get the best measurements. On the other hand, NDIR and Pellistor sensors should be switched on for a couple of minutes prior getting the measurement because they imply a higher power consumption. The gas sensor is switched on as follows:

```
gas_sensor.ON();
```

The `getConc()` function returns:

- concentration value in ppm or %LEL
- -1000 if I2C bus communication error

For sensor measurement, the user must call the proper function which returns a value in ppm units:

```
gas_sensor.getConc();
```

In the case of using a BME280, luxes or ultrasound sensor, the user must switch off all gases sensors prior using them in order to work properly with the Smart Cities PRO board. Therefore, after getting the measurement from the BME280/luxes/ultrasound sensor, all electrochemical gas sensor should be powered on again. The gas sensor is switched off calling the next function:

```
gas_sensor.OFF();
```



You can find a complete example code for reading electrochemical sensors in the following link:

<http://www.libelium.com/development/waspmote/examples/gp-v30-01-electrochemical-gas-sensors>

You can find a complete example code for reading NDIR sensors in the following link:

<http://www.libelium.com/development/waspmote/examples/scp-v30-02-ndir-gas-sensors>

You can find a complete example code for reading pellistor sensors in the following link:

<http://www.libelium.com/development/waspmote/examples/scp-v30-03-pellistor-gas-sensors>

### 6.2.3. Temperature, humidity and pressure sensor (BME280)

Regarding the BME280 sensor, the user must define an object from the `bmeCitiesSensor` class. The user must also indicate the socket used in the class constructor. The available sockets for the BME sensor are: sockets 1, 2, 3, 4 and 5 for the OEM line; and sockets A, B, C, E and F for the Plug and Sense! line. For instance:

```
bmeCitiesSensor bme(SOCKET_A);
```

The next lines describe how to switch on the sensor, get a measurement and switch it off to save energy. The values returned by the reading functions are float variable type:

```
bme.ON();  
bme.getTemperature();  
bme.getHumidity();  
bme.getPressure();  
bme.OFF();
```

The `getTemperature()`, `getHumidity()` and `getPressure()` functions return:

- The temperature in °C, the percentage of relative humidity and pressure in Pascals
- -1000 if I2C bus communication error

You can find a complete example code for reading the BME280 sensor in the following link:

<http://www.libelium.com/development/waspmote/examples/scp-v30-05-temperature-humidity-and-pressure-sensor>

### 6.2.4. Luxes sensor

Regarding the luxes sensor, the user must define an object from the `luxesCitiesSensor` class. The user must define the socket used in the class constructor. The available sockets for the luxes sensor are: sockets 1, 2, 3, 4 and 5 for the OEM line, and sockets A, B, C, E and F for the Plug and Sense! line. For instance:

```
luxesCitiesSensor luxes(SOCKET_E);
```

The next lines describe how to switch on the sensor, get a measurement and switch it off to save energy. The value returned by the reading function is a `uint32_t` variable type:

```
luxes.ON();  
luxes.getLuminosity();  
luxes.OFF();
```

The `getLuminosity()` function returns:

- luminosity in luxes
- -1000 if I2C bus communication error

You can find a complete example code for reading the luminosity in the following link:

[www.libelium.com/development/waspmote/examples/scp-v30-07-luxes-sensor](http://www.libelium.com/development/waspmote/examples/scp-v30-07-luxes-sensor)

## 6.2.5. Ultrasound sensor

Regarding the ultrasound sensor, the user must define an object from the `ultrasoundCitiesSensor` class. The user must define the socket used in the class constructor. The available sockets for the ultrasound sensor are: sockets 1, 2, 3, 4 and 5 for the OEM line, and sockets A, B, C, E and F for the Plug and Sense! line. For instance:

```
ultrasoundCitiesSensor ultrasound(SOCKET_E);
```

The next lines describe how to switch on the sensor, get a measurement and switch it off to save energy. The value returned by the reading function is a `uint16_t` variable type:

```
ultrasound.ON();  
ultrasound.getDistance();  
ultrasound.OFF();
```

The `getDistance()` function returns:

- distance in centimeters
- -1000 if I2C bus communication error

You can find a complete example code for reading the distance in the following link:

[www.libelium.com/development/waspmote/examples/scp-v30-06-ultrasound-sensor](http://www.libelium.com/development/waspmote/examples/scp-v30-06-ultrasound-sensor)

## 6.2.6. Particle Matter sensor

When using the Particle Matter Sensor on Plug&Sense!, remember it is mandatory to include the WaspPM library by introducing the next line at the beginning of the code:

```
#include <WaspPM.h>
```

WaspPM is a new library that replaces the WaspOPC\_N2 library in order to be able to read both the OPC\_N2 sensor and the OPN\_N3 sensor.

### Library variables

The WaspPM library has some variables used by the functions to store the data received from the OPC-N3 sensor. These variables are listed in the table below:

Variable	Type of variable	Description	Functions that updated it
<code>_bin[24]</code>	Array of unsigned short	Number of particles detected for each bin. It is splited in <code>_binL[16]</code> and <code>_binH[8]</code> variables	<code>getPM()</code>
<code>_binL[16]</code>	Array of unsigned short	First 16 bins	<code>getPM()</code>
<code>_binH[8]</code>	Array of unsigned short	Last 8 bins	<code>getPM()</code>
<code>_temp</code>	float	Temperature from sensor in Celsius degrees.	<code>getPM()</code>
<code>_hum</code>	float	Humidity from sensor in %RH.	<code>getPM()</code>
<code>_bin1_MToF</code>	Unsigned short	Represents the average amount of time that particles sized in the stated bin took to cross the OPS's laser beam. Each value is in $\mu\text{s}$ multiplied by 3.	<code>getPM()</code>
<code>_bin3_MToF</code>	Unsigned short	Represents the average amount of time that particles sized in the stated bin took to cross the OPS's laser beam. Each value is in $\mu\text{s}$ multiplied by 3.	<code>getPM()</code>
<code>_bin5_MToF</code>	Unsigned short	Represents the average amount of time that particles sized in the stated bin took to cross the OPS's laser beam. Each value is in $\mu\text{s}$ multiplied by 3.	<code>getPM()</code>
<code>_bin7_MToF</code>	Unsigned short	Represents the average amount of time that particles sized in the stated bin took to cross the OPS's laser beam. Each value is in $\mu\text{s}$ multiplied by 3.	<code>getPM()</code>
<code>_PM1</code>	float	The mass (in $\mu\text{g}/\text{m}^3$ ) of all particles below $1 \mu\text{m}$ in size.	<code>getPM()</code>
<code>_PM2_5</code>	float	The mass (in $\mu\text{g}/\text{m}^3$ ) of all particles below $2.5 \mu\text{m}$ in size.	<code>getPM()</code>
<code>_PM10</code>	float	The mass (in $\mu\text{g}/\text{m}^3$ ) of all particles below $10 \mu\text{m}$ in size.	<code>getPM()</code>
<code>_opcModel</code>		Represents the particle matter sensor model. 2 for OPC-N2 and 3 for OPC-N3.	<code>getPM()</code>

Figure: Variables from the WaspPM library

**Note:** `_temp` and `_hum` variables are not available for OPC\_N2 sensor. The OPC\_N2 sensor measure 16 bins instead of 24. Consequently, the `_binH` variable and the last 8 bytes of `_bin` variable will be zero.

## Initializing the sensor

Before reading the concentration values, the sensor must be powered using the function `ON()`. Unlike with other sensor boards, the user does not need to power on the board. The API library performs the next tasks in the power-on process from each sensor:

- Powers on the board (if necessary)
- Powers on the sensor
- Configures the communication bus and checks if the sensor is ready to work.

```
PM.ON();
```

The function returns:

- 0 if the sensor does not init correctly
- 1 if init OK

If a sensor for Gases PRO v1 is used, the `ON()` function must include the parameter '0' or 'PM\_SPI\_MODE'. So, the function to use should be:

```
PM.ON(0);
```

or

```
PM.ON(PM_SPI_MODE);
```

## Switching the sensor off

In order to save battery, the sensor can be powered off using the function `OFF()`. Unlike other sensor boards, the user does not need to power off the board. The API library powers off the board automatically when the last sensor is turned off.

```
PM.OFF();
```

## Reading bin and PM values

The functions `getPM(timeSample)` and `getPM(waitSample, timeSample)` perform a measure of the particles from the atmosphere. `timeSample` is the period in milliseconds to sample the air absorbed by the built-in fan. `waitSample` is a time in milliseconds with the fan powered on before the sample measurement.

```
// Reads PM and bin values with a period of 5 seconds
PM.getPM(5000);
// Reads PM and bin values with a period of 9 seconds and a wait sample of 5 seconds
PM.getPM(5000, 9000);
```

The function returns:

- 1 if OK
- 4 if error with the parameters
- 100 if error sending the command digital pot on
- 101 if error receiving data
- 102 if error sending the command read histogram
- 103 if error receiving data
- 104 if error sending the command read histogram
- 105 if error receiving data
- 106 if error sending the command digital pot off
- 107 if error receiving data

If the function ends successfully, the next variables will be updated:

- `_bin`
- `_binL`
- `_binH`
- `_temp`
- `_hum`
- `_bin1_MToF`
- `_bin3_MToF`
- `_bin5_MToF`
- `_bin7_MToF`
- `_PM1`
- `_PM2_5`
- `_PM10`
- `_opcModel`

### Reading the information string

The OPC-N3 sensor stores a string (61 bytes) with information about the sensor model and the firmware. This string can be read using the function `getInfoString(string_pointer)` and passing a string pointer as parameter. The information will be stored in the string pointer.

```
char information[61];  
// Reads the configuration variables  
PM.getInfoString(information);  
// Prints the string  
USB.println(information);
```

The function returns:

- 1 if OK
- -1 if error sending the command

### Reading the serial number

The OPC-N3 sensor stores a string (61 bytes) with the serial number information. This string can be read using the function `readSerialNumber(string_pointer)` and passing a string pointer as parameter. The information will be stored in the string pointer.

```
char serial_number[61];  
// Reads the serial number  
PM.readSerialNumber(serial_number);  
// Prints the string  
USB.println(serial_number);
```

The function returns:

- 1 if OK
- -1 if error sending the command

**Note:** That function isn't available for OPC-N2 sensors with old firmware version.

The files of the sensor itself are: `WaspPM.cpp`, `WaspPM.h`

They can be downloaded from: [http://www.libelium.com/development/waspmote/sdk\\_and\\_applications](http://www.libelium.com/development/waspmote/sdk_and_applications)

## 7. Consumption

### 7.1. Consumption table

In the following table, the consumption shown by the board when active is detailed, the minimum consumption (constant, fixed by the permanently active components, such as the adaptation electronics) and the individual consumptions of each of the sensors connected alone to the board (the total consumption of the board with a determined sensor will be calculated as the sum of the constant minimum consumption of the board plus the minimum consumption of the group to whom the sensor belongs plus the consumption of the sensor).

Remember that the board's power can be completely disconnected, reducing the consumption to zero, powering off all the sensors.

Sensor	Switch on
Minimum (constant, due to the Sensor Board)	4-6 $\mu$ A
Temperature, Humidity and Pressure	2.8 – 4.2 $\mu$ A
Luminosity	240 $\mu$ A
Ultrasound	2 mA (50 mA peaks)
Carbon Monoxide (CO) for high concentrations	351 $\mu$ A
Carbon Monoxide (CO) for low concentrations	312 $\mu$ A
Carbon Dioxide (CO <sub>2</sub> )	85 mA
Molecular Oxygen (O <sub>2</sub> )	332 $\mu$ A
Ozone (O <sub>3</sub> )	<1 mA
Nitric Oxide (NO) for low concentrations	392 $\mu$ A
Nitric Dioxide high accuracy (NO <sub>2</sub> )	330 $\mu$ A
Sulfur Dioxide high accuracy (SO <sub>2</sub> )	280 $\mu$ A
Ammonia (NH <sub>3</sub> ) for low concentrations	338 $\mu$ A
Ammonia (NH <sub>3</sub> ) for high concentrations	338 $\mu$ A
Methane (CH <sub>4</sub> ) and other combustible gases	68 mA
Molecular Hydrogen (H <sub>2</sub> )	520 $\mu$ A
Hydrogen Sulfide (H <sub>2</sub> S)	352 $\mu$ A
Hydrogen Chloride (HCl)	341 $\mu$ A
Hydrogen Cyanide (HCN)	327 $\mu$ A
Phosphine (PH <sub>3</sub> )	361 $\mu$ A
Ethylene Oxide (ETO)	360 $\mu$ A
Chlorine (Cl <sub>2</sub> )	353 $\mu$ A
Particle Matter – Dust	270 mA @ 5 V

Figure: Consumption for each sensor

## 8. API changelog

Keep track of the software changes on this link:

[www.libelium.com/development/waspmote/documentation/changelog/#SmartCities](http://www.libelium.com/development/waspmote/documentation/changelog/#SmartCities)

## 9. Documentation changelog

### From v7.5 to v7.6

- Added references to the new OPC-N3 sensor (OPC-N2 evolution)
- Added references to new LoRaWAN ASIA-PAC / LATAM module
- Added references to new Hive service
- Deleted references to the discontinued RS-232 module

### From v7.4 to v7.5

- Added explanation to the Noise Level Sensor test report
- Deleted references to the discontinued sensor Carbon Monoxide (CO) for high concentrations
- Added references to new Sigfox AU / APAC / LATAM module
- Added references to new LoRaWAN AU and IN modules
- Deleted references to the discontinued internal solar panel

### From v7.3 to v7.4

- Added comparative analysis between Alphasense' and Libelium's hardware
- Added explanation about I2C error code

### From v7.2 to v7.3

- Added changes in the Smart Cities PRO library
- Added recommendations for electrochemical sensors
- Added references to the Programming Cloud Service
- Added references to the External Battery Module accessory
- The operating temperature range and maximum recharging current were updated

### From v7.1 to v7.2:

- Added references to the Ammonia (NH<sub>3</sub>) Gas Sensor for high concentrations
- Added references for the new GPS accessory for Plug & Sense!

### From v7.0 to v7.1:

- Added references to the integration of Industrial Protocols for Plug & Sense!



## 10. Certifications

Libelium offers 2 types of IoT sensor platforms, Waspote OEM and Plug & Sense!:

- **Waspote OEM** is intended to be used for research purposes or as part of a major product so it needs final certification on the client side. More info at: [www.libelium.com/products/waspote](http://www.libelium.com/products/waspote)
- **Plug & Sense!** is the line ready to be used out-of-the-box. It includes market certifications. See below the specific list of regulations passed. More info at: [www.libelium.com/products/plug-sense](http://www.libelium.com/products/plug-sense)

Besides, Meshlium, our multiprotocol router for the IoT, is also certified with the certifications below. Get more info at:

[www.libelium.com/products/meshlium](http://www.libelium.com/products/meshlium)

List of certifications for Plug & Sense! and Meshlium:

- CE (Europe)
- FCC (US)
- IC (Canada)
- ANATEL (Brazil)
- RCM (Australia)
- PTCRB (cellular certification for the US)
- AT&T (cellular certification for the US)



Figure: Certifications of the Plug & Sense! product line

You can find all the certification documents at:

[www.libelium.com/certifications](http://www.libelium.com/certifications)

## 11. Maintenance

- In this section, the term “Wasmote” encompasses both the Wasmote device itself as well as its modules and sensor boards.
- Take care with the handling of Wasmote, do not drop it, bang it or move it sharply.
- Avoid putting the devices in areas of high temperatures since the electronic components may be damaged.
- The antennas are lightly threaded to the connector; do not force them as this could damage the connectors.
- Do not use any type of paint for the device, which may damage the functioning of the connections and closure mechanisms.

## 12. Disposal and recycling

- In this section, the term “Wasmote” encompasses both the Wasmote device itself as well as its modules and sensor boards.
- When Wasmote reaches the end of its useful life, it must be taken to a recycling point for electronic equipment.
- The equipment has to be disposed on a selective waste collection system, different to that of urban solid waste. Please, dispose it properly.
- Your distributor will inform you about the most appropriate and environmentally friendly waste process for the used product and its packaging.